



Single-Phase Automotive LED Boost Driver with Limp Home Mode

ASL150ySHN

Last Updated: Jul 20, 2023

The ASL1500SHN is a highly integrated and flexible single-phase DC-to-DC boost converter IC. It has an SPI interface allowing control and diagnostic communication with an external MCU. It drives one external low-side N channel MOSFET from an internally regulated adjustable supply to drive either logic or standard level MOSFET. The flexible driver can be configured, via the SPI interface, as a single output converter, or with multiple combinations of number of outputs and phases. Read More on the [\\$AUTOHREFLINK\[1510841619661695519510:C:ASL1500SHN Data Sheet\]](#).

The ASL1507SHN is a single-phase boost converter IC with a Limp Home mode feature. It provides an SPI interface for extensive control and diagnostic communication with an external microcontroller and integrates a customer programmable Limp Home mode. The driver IC allows configurable operation during the Limp Home mode in case SPI communication with the microcontroller has failed. Once the loss of SPI communication is detected, the Limp Home mode gets activated. Read More on the [\\$AUTOHREFLINK\[1530906916358720024685:C:ASL1507SHN; ASL2507SHN Data Sheet\]](#).

Led Lighting System Block Diagram Block Diagram

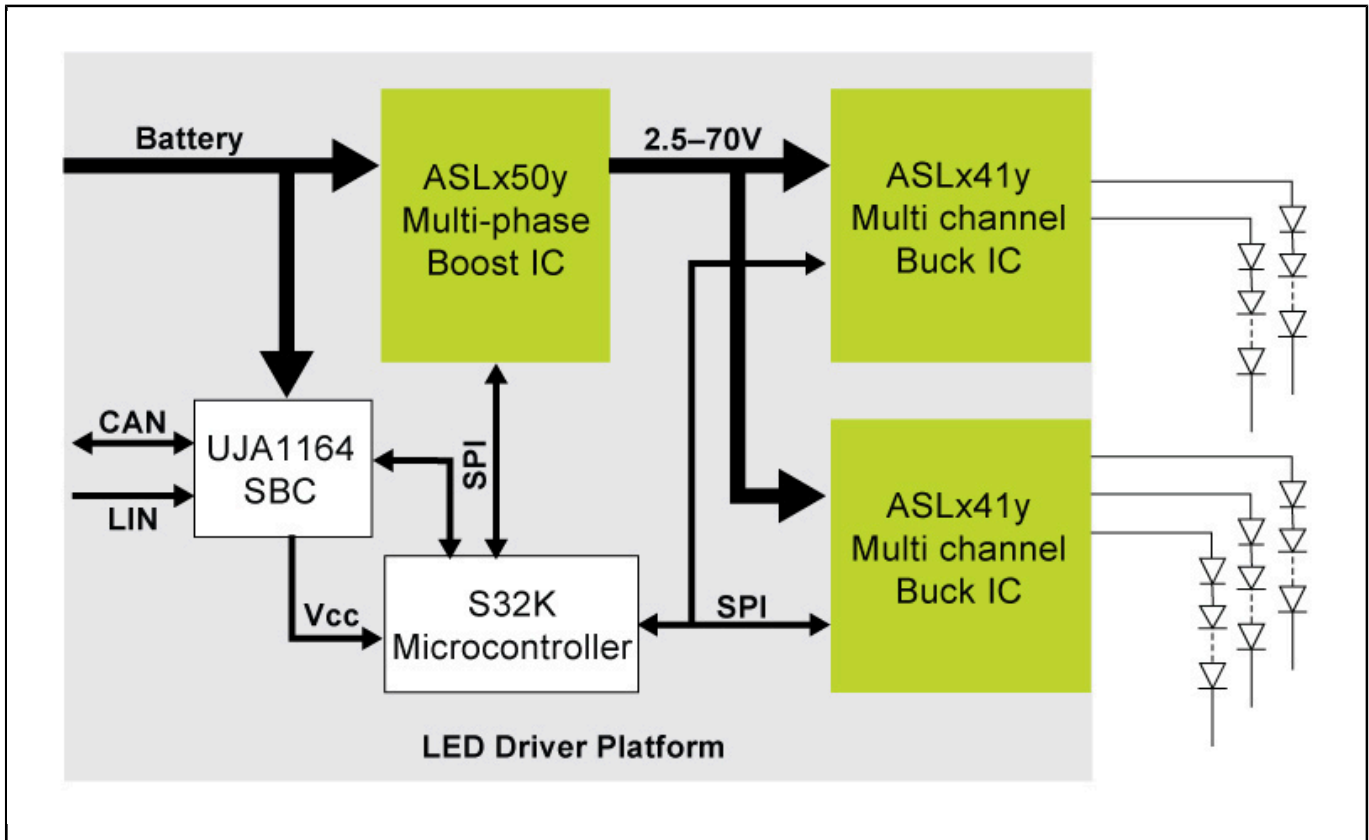

Single-Phase Automotive LED Boost Driver Block Diagram

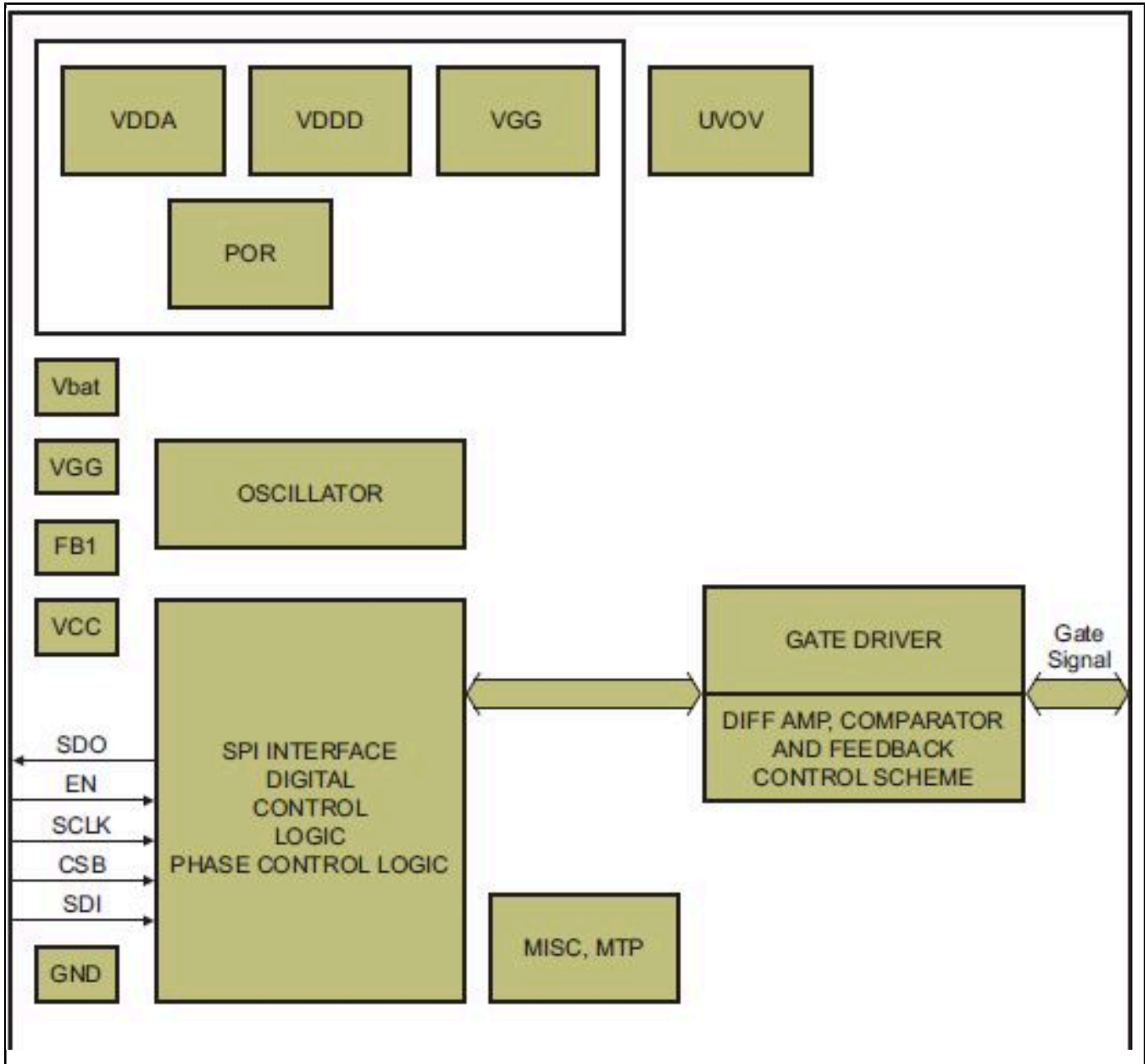

View additional information for [Single-Phase Automotive LED Boost Driver with Limp Home Mode](#).

Note: The information on this document is subject to change without notice.

www.nxp.com

NXP and the NXP logo are trademarks of NXP B.V. All other product or service names are the property of their respective owners. The related technology may be protected by any or all of patents, copyrights, designs and trade secrets. All rights reserved. © 2024 NXP B.V.