



Four-Phase Automotive LED Boost Driver

ASL4500SHN

Last Updated: Jul 20, 2023

The ASL4500SHN is a highly integrated and flexible four-phase DC-to-DC boost converter IC. It has an SPI interface allowing control and diagnostic communication with an external microcontroller.

It is designed primarily for use in automotive LED lighting applications and provides an optimized supply voltage for ASLx41xSHN Multi-channel LED Buck Driver.

The ASL4500SHN has a fixed frequency peak current mode control with parabolic/non-linear slope compensation. It can operate with input voltages from 5.5 V to 40 V. It can be configured via SPI for output voltages of up to 80 V, to power the LED buck driver IC.

The ASL4500SHN is a four-phase converter which can have two independent outputs. The driver has the flexibility to be configured, via the SPI interface, as a single output converter, or with multiple combinations of number of outputs and phases.

The ASL4500SHN boost converter can drive up to four external low-side N channel MOSFETs from an internally regulated adjustable supply. It can be used to drive either logic or standard level MOSFETs.

The integrated SPI interface also allows for programming the supply under/over voltage range, output voltage range and DC-to-DC switching frequency. It enables the optimization of external components and flexibility for EMC design. This interface can also be used to provide diagnostic information such as the driver temperature.

Additional features include protection against load dump transient voltages of up to 60 V and thermal shutdown when the junction temperature of the ASL4500SHN exceeds +175 °C.

The device is housed in a very small HVQFN32 pin package and is designed to meet the stringent requirements of automotive applications. It is fully AEC Q100 grade 1 qualified. It operates over the -40 °C to +125 °C ambient automotive temperature range.

Led Lighting System Block Diagram Block Diagram

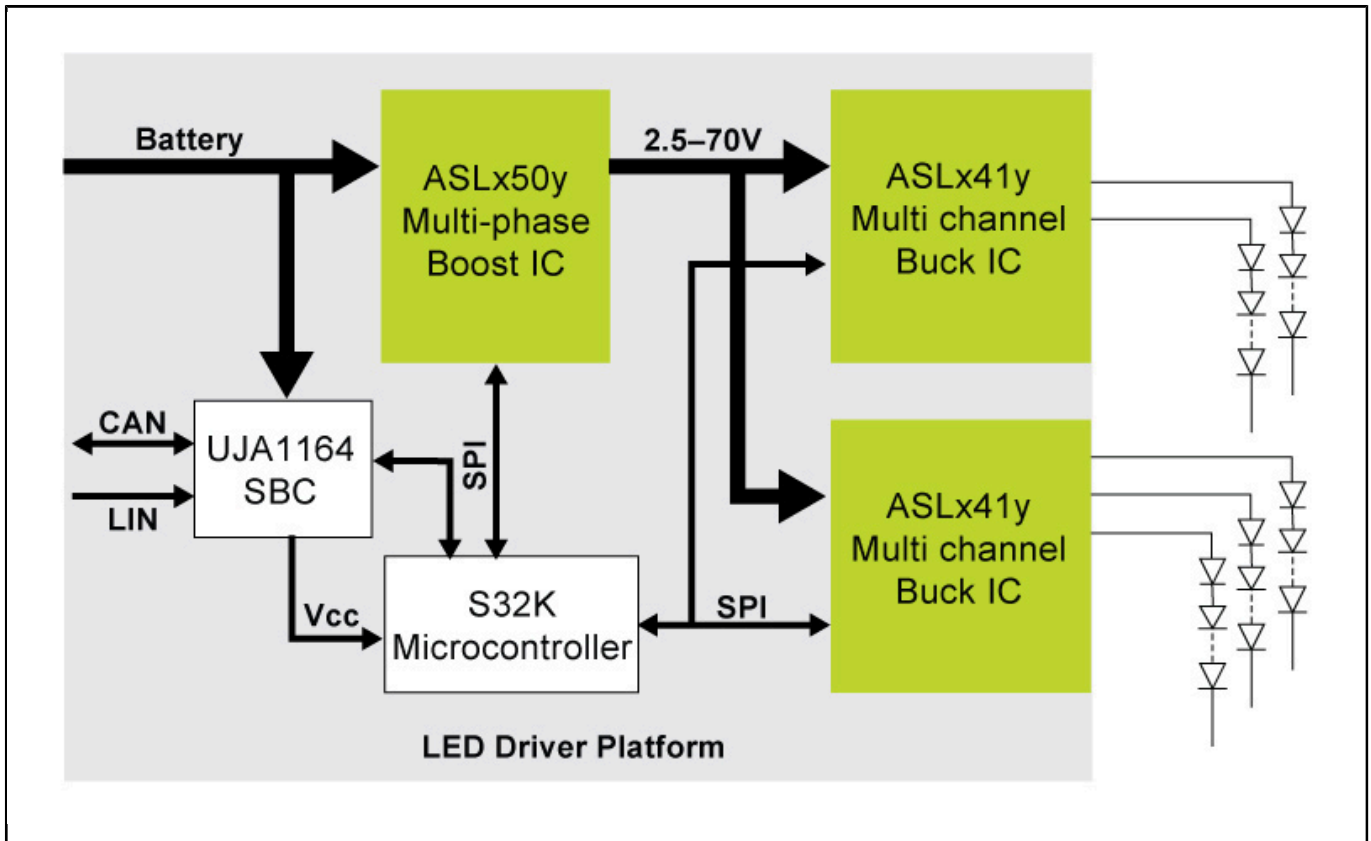

ASL4500SHN Block Diagram Block Diagram

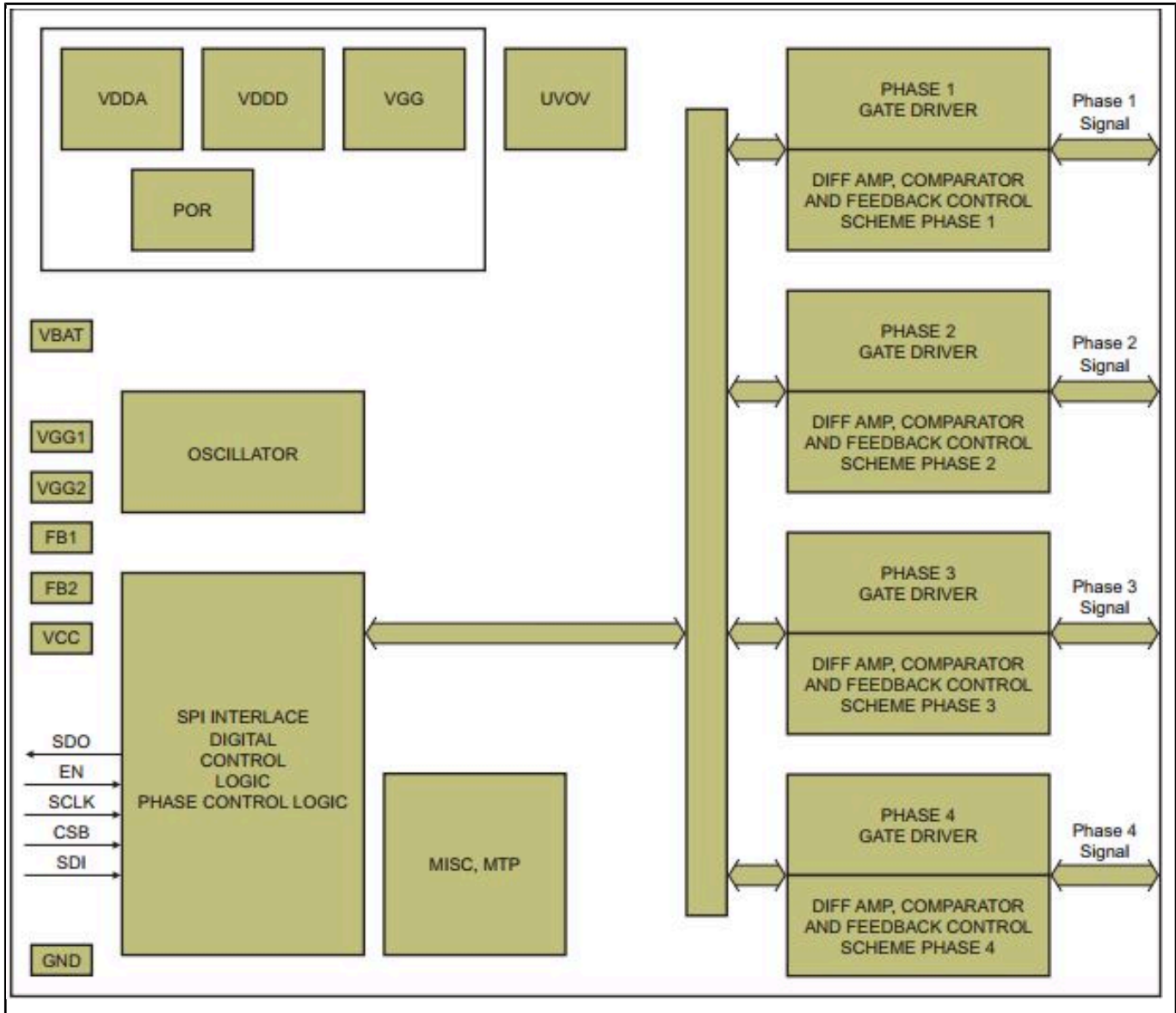

View additional information for [Four-Phase Automotive LED Boost Driver](#).

Note: The information on this document is subject to change without notice.

www.nxp.com

NXP and the NXP logo are trademarks of NXP B.V. All other product or service names are the property of their respective owners. The related technology may be protected by any or all of patents, copyrights, designs and trade secrets. All rights reserved. © 2024 NXP B.V.