



USB PD and Type-C Current-Limited Power Switch

NX5P3290UK

Last Updated: Mar 22, 2024

The NX5P3290 is a precision adjustable current-limited power switch for USB PD application. The device includes under voltage lockout, over-temperature protection, and reverse current protection circuits to automatically isolate the switch terminals when a fault condition occurs. The 29 V tolerance on VBUS pin ensures the device is able to work on a USB PD port; a current limit input (ILIM) pin defines the over-current limit threshold; an open-drain fault output (FLT) indicates when a fault condition has occurred.

The over-current limit threshold can be programmed from 400 mA to 3.3 A, using an external resistor between the ILIM pin and GND pin. In the over current condition, the device will clamp the output current to the value set by ILIM and keep the switch on while asserting the FLT flag.

To minimize current surges during normal turn on, the device has built in soft start by limiting the power switch turn on slew rate. However, user can disable the soft start and request a fast output by pulling FO pin HIGH.

A fast RCP recovery circuit has been added to the switch to prevent any reverse current flowing back to power source at all times. When exiting from reverse current protection state, the power MOSFET will turn on within 50 us. The fast RCP recovery ensures the voltage on VBUS doesn't drop too much in a power source swap application.

NX5P3290 is offered in a 2.05 x 2.05 mm, 16 bump WLCSP package.

NX5P3290 Block Diagram Block Diagram

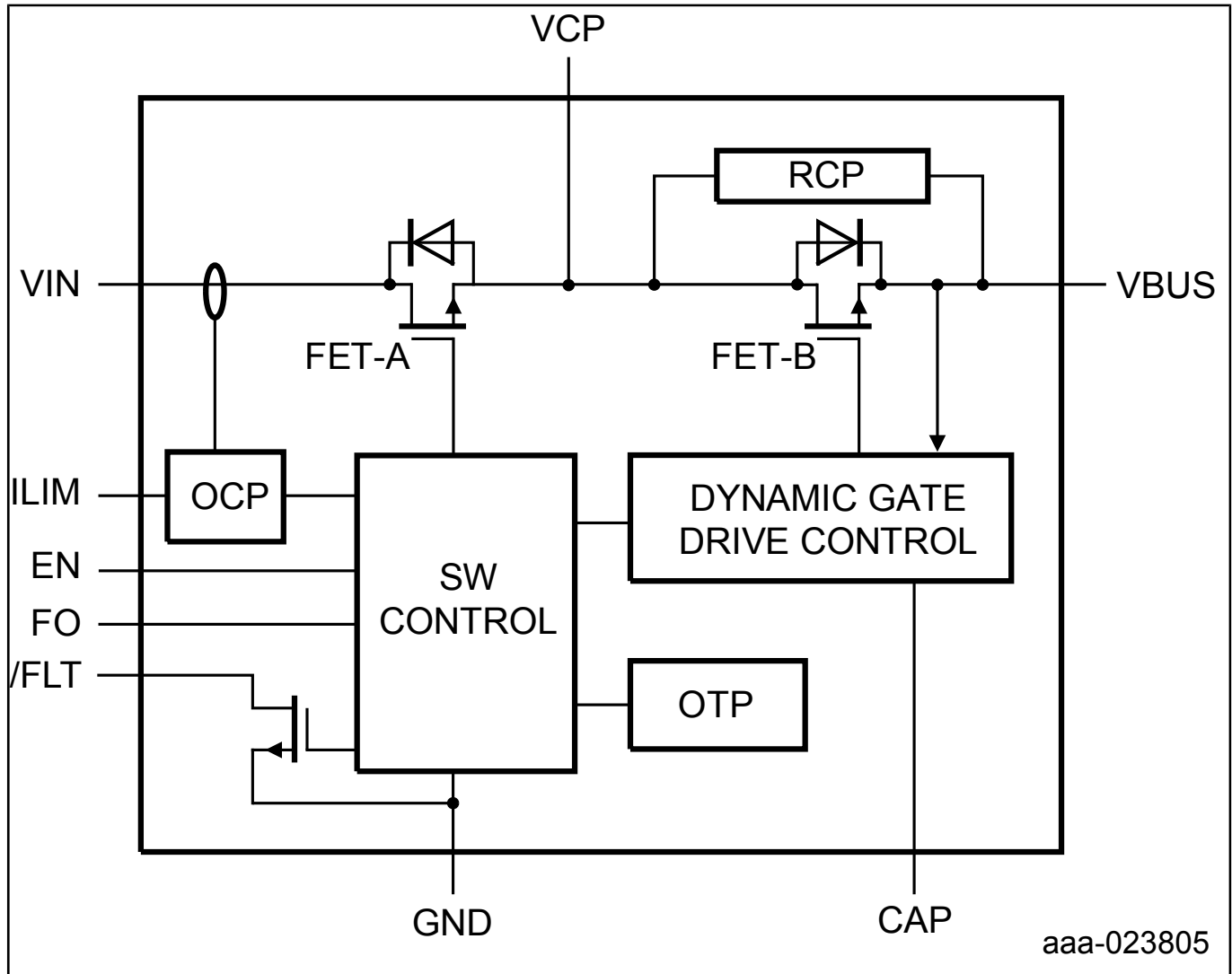

View additional information for [USB PD and Type-C Current-Limited Power Switch](#).

Note: The information on this document is subject to change without notice.

www.nxp.com

NXP and the NXP logo are trademarks of NXP B.V. All other product or service names are the property of their respective owners. The related technology may be protected by any or all of patents, copyrights, designs and trade secrets. All rights reserved. © 2024 NXP B.V.