



# Automotive Accurate RTC with Integrated Quartz Crystal

## PCA2129

新規採用非推奨

このページでは、新規設計を推奨しない製品に関する情報を掲載しています。

Last Updated: Apr 12, 2024

PCA2129T device is "Not Recommended for New Designs", please use the replacement part PCA2131TF

The PCA2129 is a CMOS Real Time Clock (RTC) and calendar with an integrated Temperature Compensated Crystal (Xtal) Oscillator (TCXO) and a 32.768 kHz quartz crystal optimized for very high accuracy and very low power consumption. The PCA2129 has a selectable I<sup>2</sup>C-bus or SPI-bus, a backup battery switch-over circuit, a programmable watchdog function, a timestamp function, and many other features.

# PCA2129 Block Diagram Block Diagram

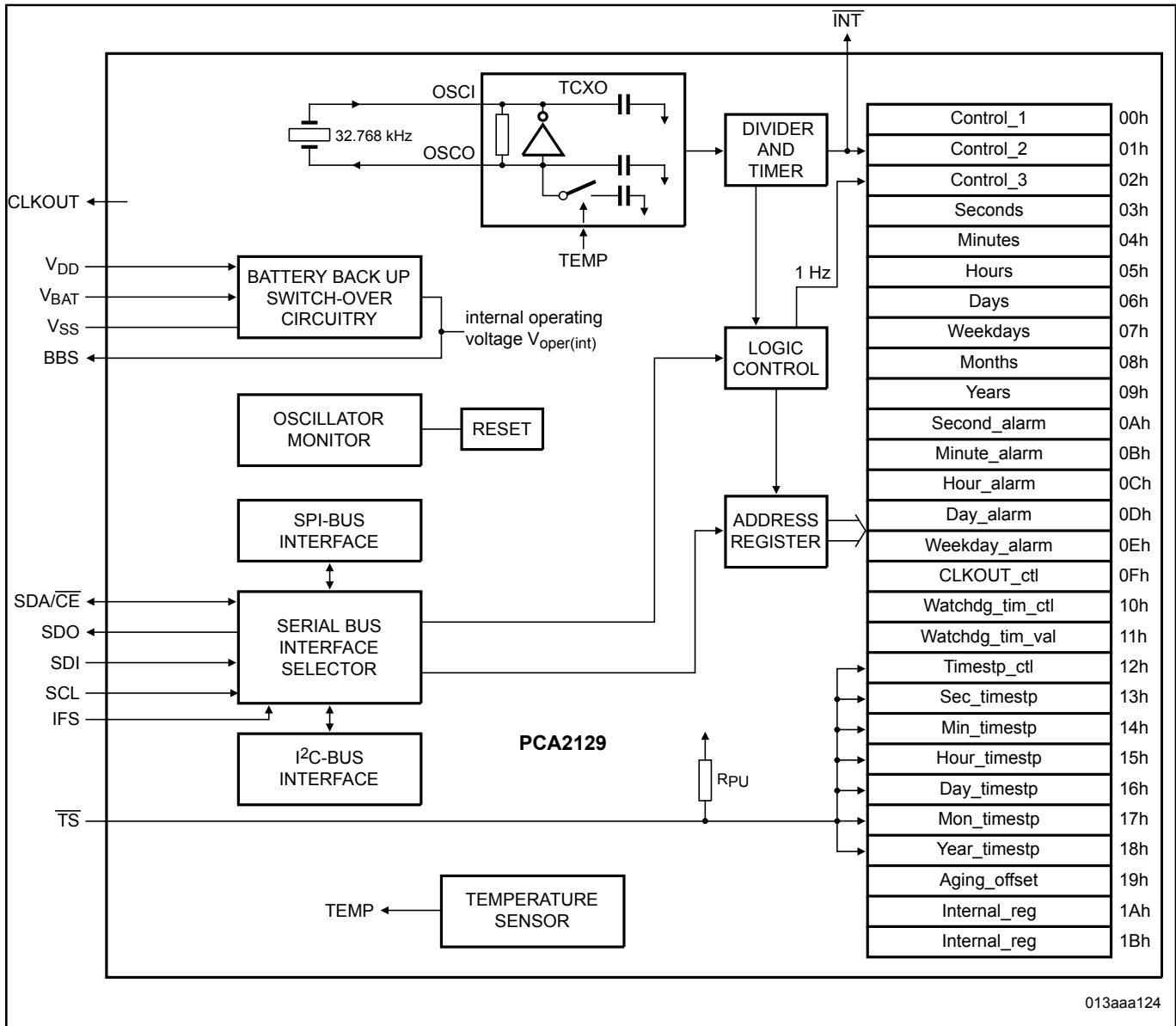

View additional information for [Automotive Accurate RTC with Integrated Quartz Crystal](#).

**Note:** The information on this document is subject to change without notice.

**www.nxp.com**

NXP and the NXP logo are trademarks of NXP B.V. All other product or service names are the property of their respective owners. The related technology may be protected by any or all of patents, copyrights, designs and trade secrets. All rights reserved. © 2024 NXP B.V.