



# Low-Voltage, 8-Bit I<sup>2</sup>C-Bus and SMBus I/O Expander with Interrupt Output, Reset and Configuration Registers

## PCA6408A

Last Updated: Mar 8, 2023

The PCA6408A is an 8-bit general purpose I/O expander that provides remote I/O expansion for most microcontroller families via the I<sup>2</sup>C-bus interface.

NXP I/O expanders provide a simple solution when additional I/Os are needed while keeping interconnections to a minimum, for example, in battery-powered mobile applications for interfacing to sensors, push buttons, keypad, etc. In addition to providing a flexible set of GPIOs, it simplifies interconnection of a processor running at one voltage level to I/O devices operating at a different (usually higher) voltage level. The PCA6408A has built-in level shifting feature that makes these devices extremely flexible in mixed signal environments where communication between incompatible I/O voltages is required. Its wide VDD range of 1.65 V to 5.5 V on the dual power rail allows seamless communications with next-generation low voltage microprocessors and microcontrollers on the interface side (SDA/SCL) and peripherals at a higher voltage on the port side.

There are two supply voltages for PCA6408A: VDD(I<sup>2</sup>C-bus) and VDD(P). VDD(I<sup>2</sup>C-bus) provides the supply voltage for the interface at the controller side (for example, a microcontroller) and the VDD(P) provides the supply for core circuits and Port P. The bidirectional voltage level translation in the PCA6408A is provided through VDD(I<sup>2</sup>C-bus). VDD(I<sup>2</sup>C-bus) should be connected to the VDD of the external SCL/SDA lines. This indicates the VDD level of the I<sup>2</sup>C-bus to the PCA6408A. The voltage level on Port P of the PCA6408A is determined by the VDD(P).

The PCA6408A consists of one 8-bit Configuration (input or output selection), Input, Output, and Polarity Inversion (active HIGH) register. At power-on, the I/Os are configured as inputs. However, the system controller can enable the I/Os as either inputs or outputs by writing to the I/O configuration bits. The data for each input or output is kept in the corresponding Input or Output register. The polarity of the Input port register can be inverted with the Polarity Inversion register, saving interrupts.

The system controller can reset the PCA6408A in the event of a time-out or other improper operation by asserting a LOW in the RESET input. The power-on reset puts the registers in their default state and initializes the I<sup>2</sup>C-bus/SMBus state machine. The RESET pin causes the same reset/initialization to occur without de-powering the part.

The PCA6408A open-drain interrupt (INT) output is activated when any input state differs from its corresponding Input port register state and is used to indicate to the system controller that an input state has changed.

INT can be connected to the interrupt input of a microcontroller. By sending an interrupt signal on this line, the remote I/O can inform the microcontroller if there is incoming data on its ports without having to communicate via the I<sup>2</sup>C-bus. Thus, the PCA6408A can remain a simple target device.

The device Port P outputs have 25 mA sink capabilities for directly driving LEDs while consuming low device current.

One hardware pin (ADDR) can be used to program and vary the fixed I<sup>2</sup>C-bus address and allow up to two devices to share the same I<sup>2</sup>C-bus or SMBus.

### PCA6408A Block Diagram Block Diagram

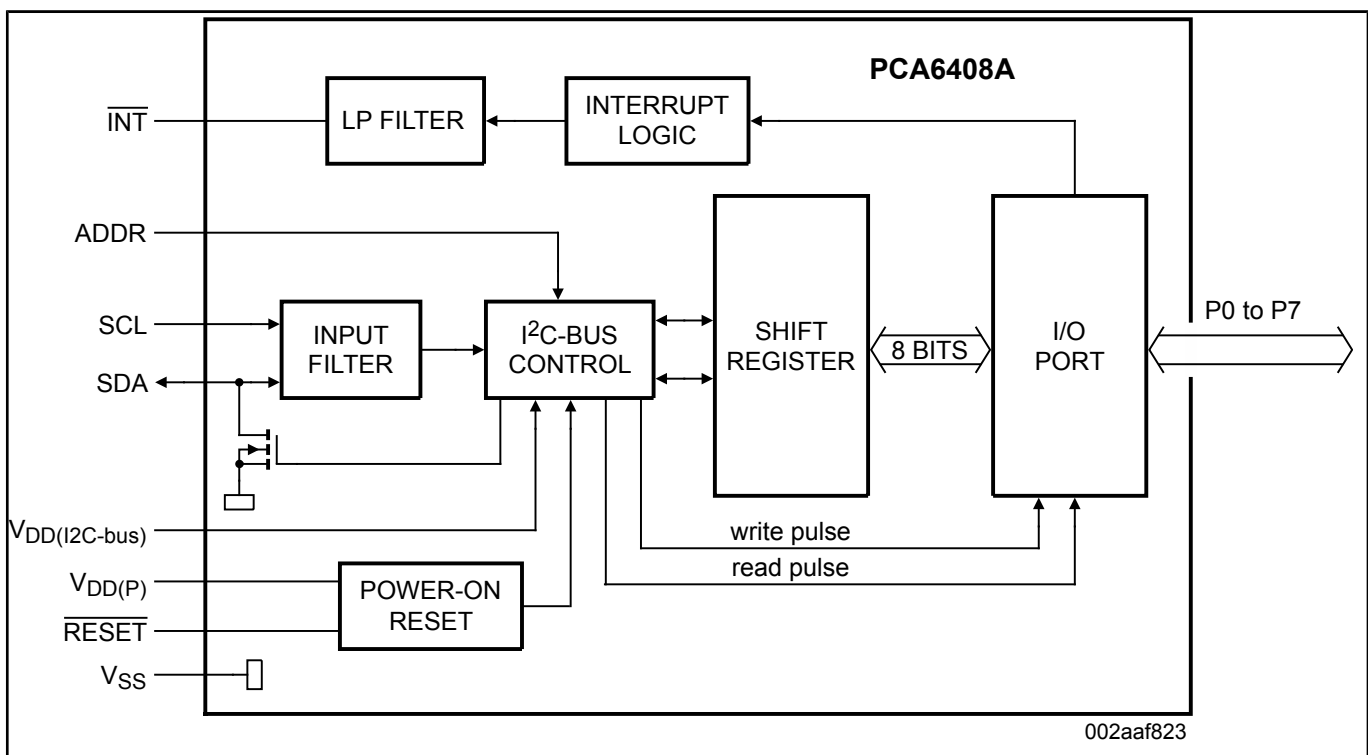

View additional information for [Low-Voltage, 8-Bit I<sup>2</sup>C-Bus and SMBus I/O Expander with Interrupt Output, Reset and Configuration Registers](#).

**Note:** The information on this document is subject to change without notice.

---

**www.nxp.com**

NXP and the NXP logo are trademarks of NXP B.V. All other product or service names are the property of their respective owners. The related technology may be protected by any or all of patents, copyrights, designs and trade secrets. All rights reserved. © 2024 NXP B.V.