



# Single Coil Wireless Power Solution

## WPS-65WS

Last Updated: May 1, 2023

65W single-coil wireless power solution includes controllers, software and hardware, all documented and fully tested to enable rapid move from prototype to production. Scalable form factor and parameters support broad range of use cases and applications like e-scooters, fixed wireless access outdoor units, vacuum cleaners, power tools, drones, and more.

WPS-65WS 65W+ Single-Coil Wireless Power Solution - Fact Sheet

## Wireless Power Voltage Block Diagram

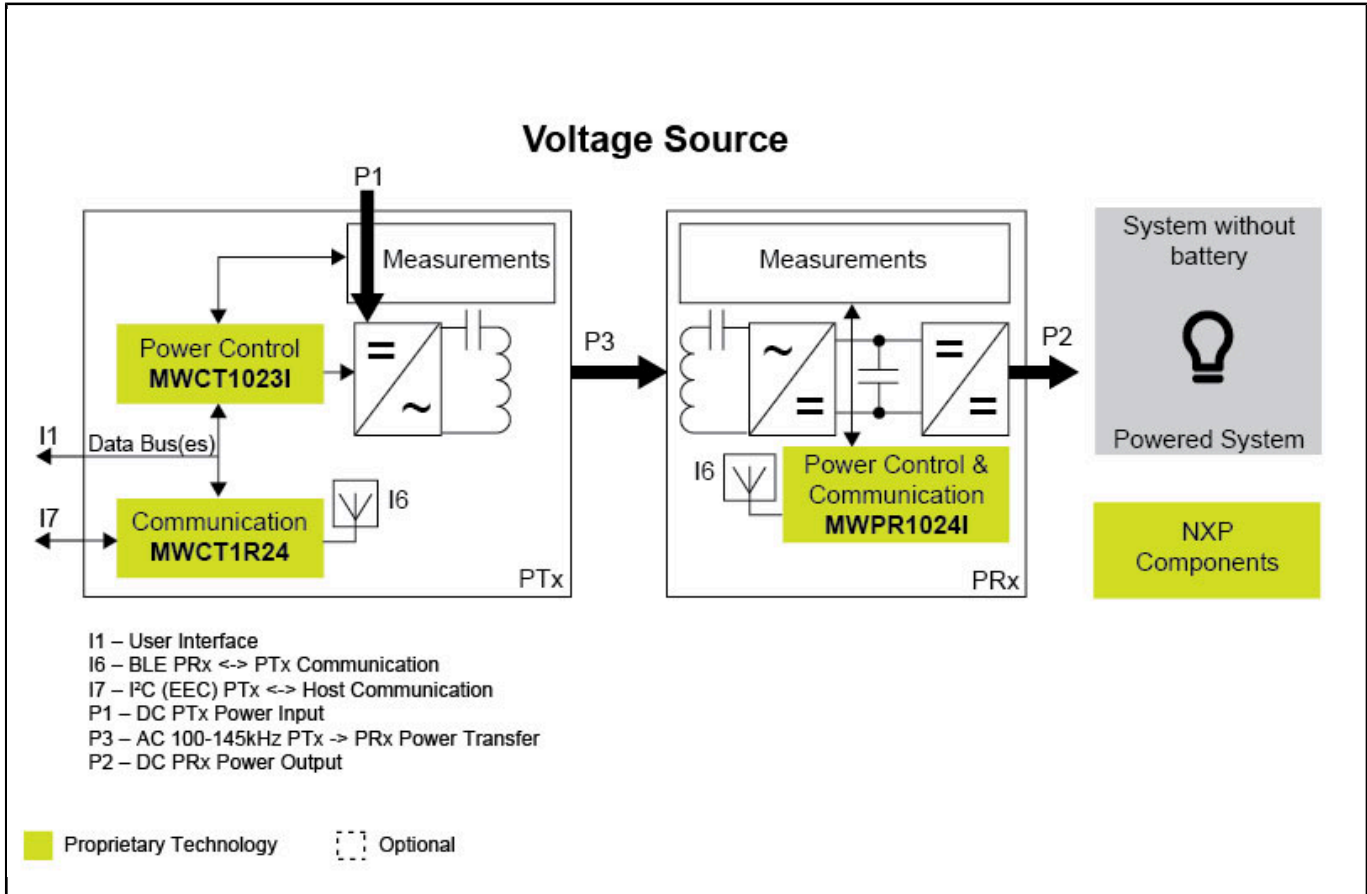

## Wireless Power Current Source Block Diagram

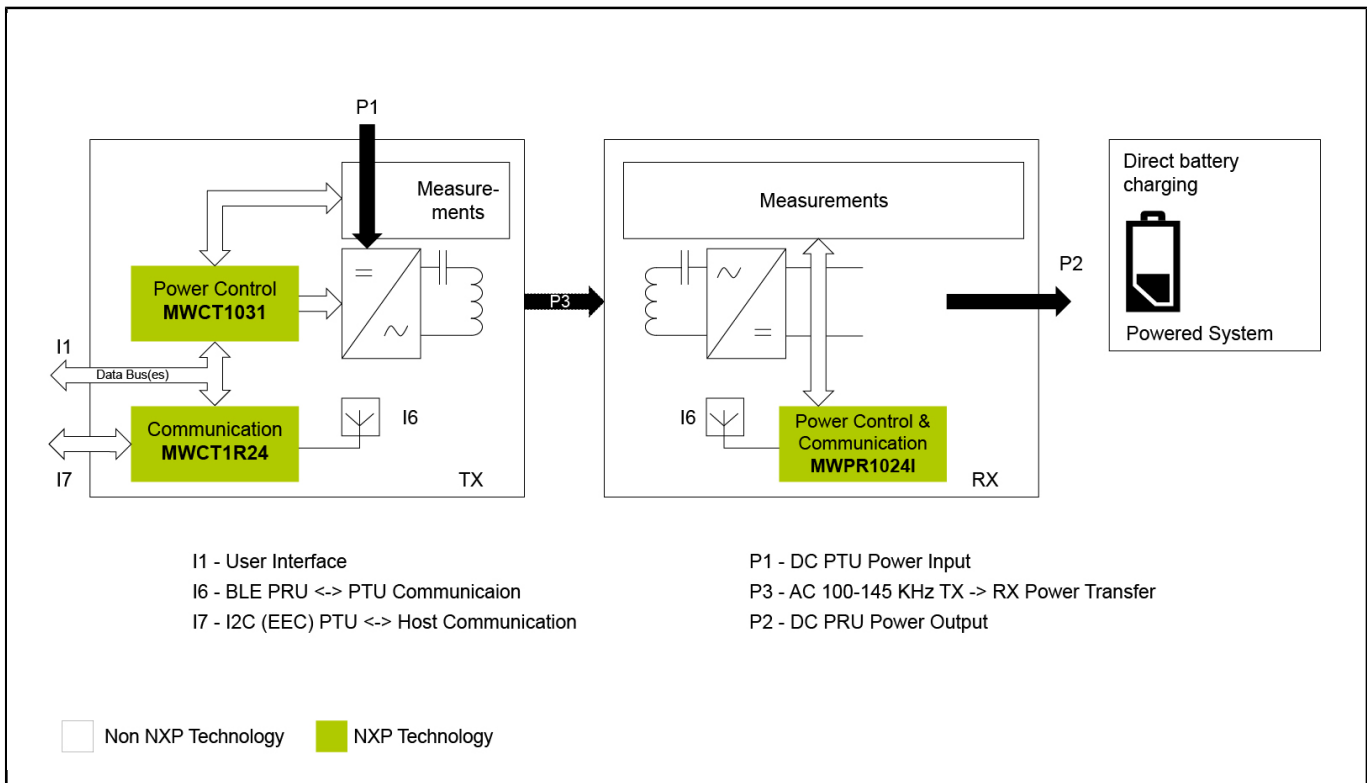

View additional information for [Single Coil Wireless Power Solution](#).

**Note:** The information on this document is subject to change without notice.

---

**[www.nxp.com](http://www.nxp.com)**

NXP and the NXP logo are trademarks of NXP B.V. All other product or service names are the property of their respective owners. The related technology may be protected by any or all of patents, copyrights, designs and trade secrets. All rights reserved. © 2024 NXP B.V.