

AN11729

BGU8309 GNSS LNA evaluation board

Rev. 2 — 12 August 2016

Application note

Document information

| Info | Content |
|----------------------------|---|
| Keywords | BGU8309, GNSS, LNA |
| Abstract | This document explains the BGU8309 GNSS LNA evaluation board |
| Ordering info | <u>Board-number:</u> OM17017 <u>12NC:</u> 9340 699 24598 |
| Contact information | For more information, please visit: http://www.nxp.com |



Revision history

| Rev | Date | Description |
|-----|----------|--|
| 2 | 20160812 | Extra PCB design recommendations added (paragraph 3.2) |
| 1 | 20160615 | First publication |

Contact information

For more information, please visit: <http://www.nxp.com>

For sales office addresses, please send an email to: salesaddresses@nxp.com

1. Introduction

NXP Semiconductors' BGU8309 Global Navigation Satellite System (GNSS) LNA Evaluation Board is designed to evaluate the performance of the GNSS LNA using:

- NXP Semiconductors' BGU8309 GNSS Low Noise Amplifier
- A matching inductor
- A decoupling capacitor

NXP Semiconductors' BGU8309 is a low-noise amplifier for mobile and wearable receiver applications in an extremely small package at 0.8 mm x 0.8 mm x 0.35 mm: SOT1226-2. The BGU8309 features a gain of 17 dB and a noise figure of 0.65 dB at a current consumption of 3.6 mA. Its sufficient linearity performance removes interference and noise from co-habitation cellular transmitters, while retaining sensitivity. The LNA and its components occupy a total PCB area of approximately 2.3 mm².

In this document, the application diagram, board layout, bill of materials, and typical results are given, as well as some explanations on GNSS related performance parameters like out-of-band input third-order intercept point O_{IIP3}, gain compression under jamming and noise under jamming.

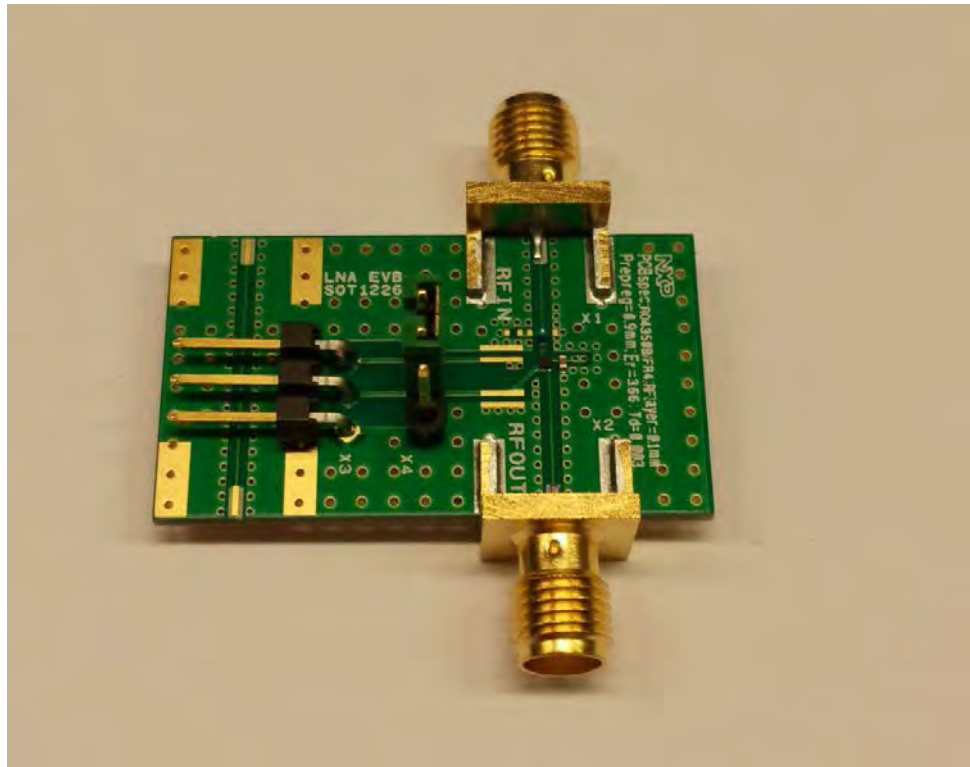

Fig 1. BGU8309 GNSS LNA evaluation board

2. General description

Modern cellular phones have multiple radio systems, so problems like co-habitation are quite common. A GNSS receiver implemented in a mobile phone requires the following factors to be taken into account.

All the different transmit signals that are active in smart phones and tablets can cause problems like inter-modulation and compression.

Since the GNSS receiver needs to receive signals with an average power level of -130 dBm, sensitivity is very important. Currently there are several GNSS chipsets on the market that can be implemented in mobile and wearable applications. Although many of these GNSS ICs do have integrated LNA front ends, the noise performance, and as a result the system sensitivity, is not always adequate. The GNSS receiver sensitivity is a measure how accurate the coordinates are calculated. The GNSS signal reception can be improved by a GNSS LNA, which improves the sensitivity by amplifying the wanted GNSS signal with a low-noise amplifier.

3. BGU8309 GNSS LNA evaluation board

The BGU8309LNA evaluation board simplifies the RF evaluation of the BGU8309 GNSS LNA applied in a GNSS front-end, often used in mobile cell phones. The evaluation board enables testing of the device RF performance and requires no additional support circuitry. The board is fully assembled with the BGU8309 including the input series inductor and decoupling capacitor. The board is supplied with two SMA connectors for input and output connection to RF test equipment. The BGU8309 can operate from a 1.5 V to 3.1 V single supply and consumes typical 3.6 mA.

3.1 Application Circuit

The circuit diagram of the evaluation board is shown in Fig 2. With jumper JU1 the enable input can be connected either to Vcc or GND.

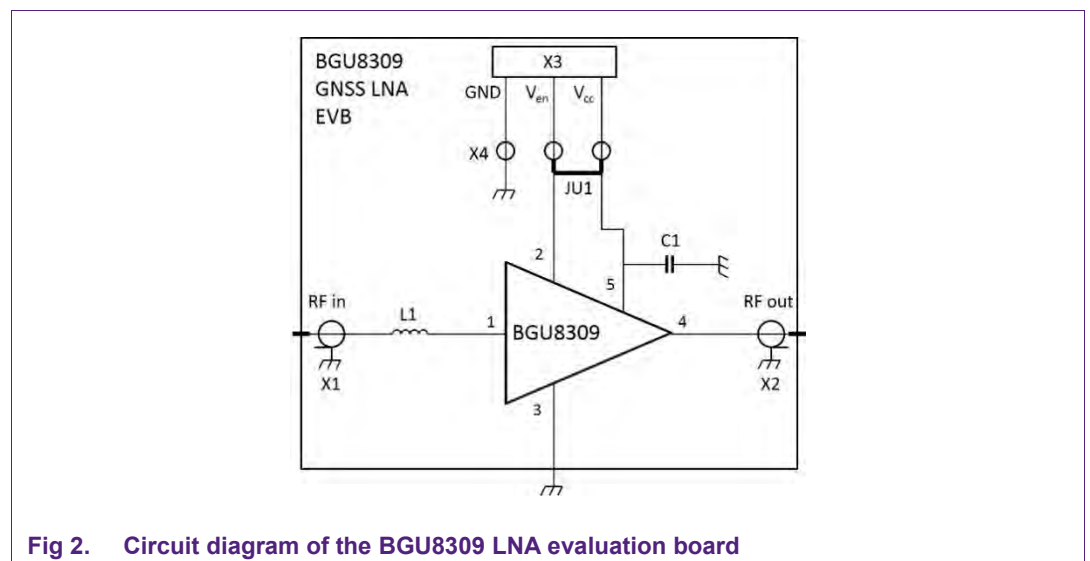

Fig 2. Circuit diagram of the BGU8309 LNA evaluation board

3.2 PCB Layout

The layout of the BGU8309 PCB is given in Fig 3. An extra 50Ω trough-line track is added to this PCB (left side) to check the board losses and matching of the 50Ω lines.

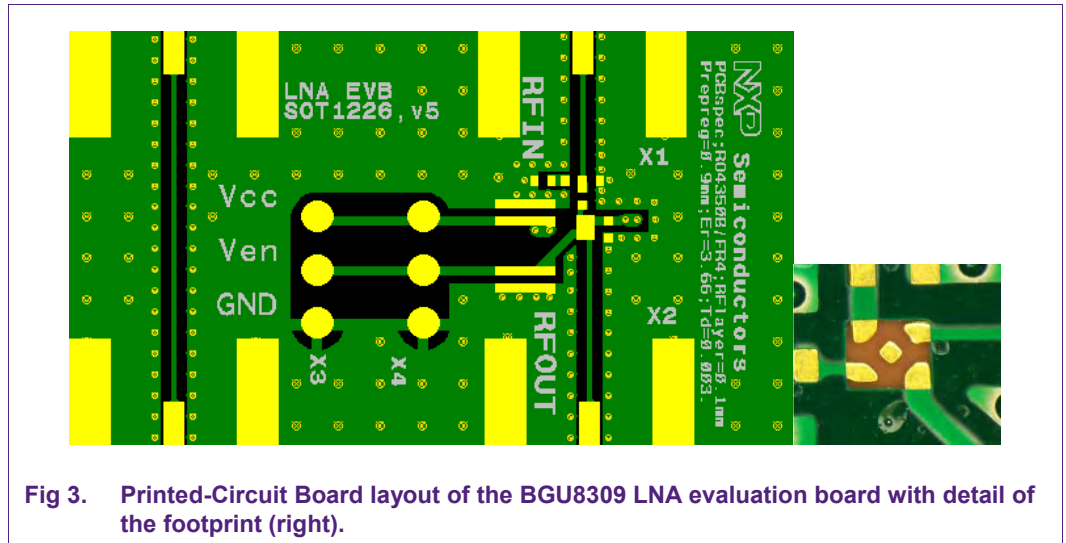
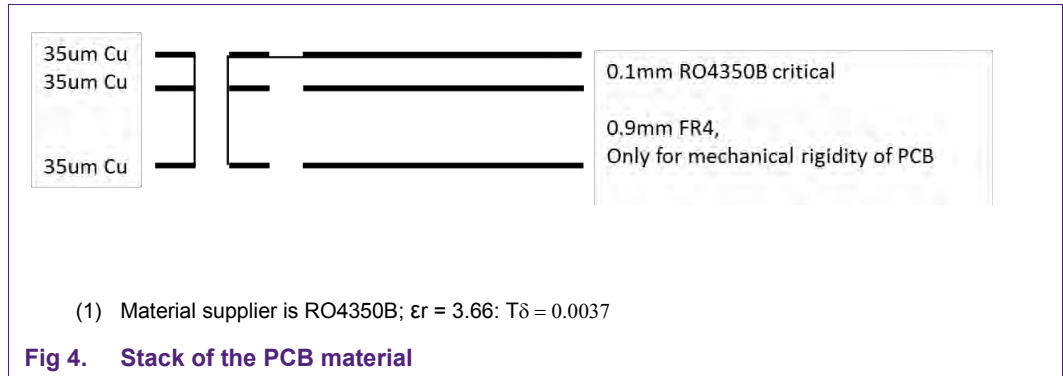

Fig 3. Printed-Circuit Board layout of the BGU8309 LNA evaluation board with detail of the footprint (right).

A good PCB layout is an essential part of an RF circuit design. The LNA evaluation board of the BGU8309 can serve as a guideline for laying out a board using the BGU8309.

- Use controlled impedance lines for all high frequency inputs and outputs.
- Bypass Vcc with decoupling capacitors, preferably located as close as possible to the device.
- For long bias lines it may be necessary to add decoupling capacitors along the line further away from the device.
- Proper grounding of the GND pins is essential for good RF performance. Either connect the GND pins directly to the ground plane or through vias, or do both, which is recommended.
- To ensure optimal performance of BGU8309 in the application it is advised to simulate the overall application performance using the S-parameter and noise models of the device, the models for the external components (SAW filter, input inductor) and the models for the PCB. Models for the BGU8309 are available via www.nxp.com.

The material that has been used for the evaluation board is Rogers RO4350B using the stack shown in Fig 4. The footprint uses a blind-via to the GND plane (metal-2).



3.3 Bill of materials

Table 1. BOM of the BGU8309 GNSS LNA evaluation board

| Designator | Description | Footprint | Value | Supplier Name/type | Comment |
|------------|------------------|---------------------------|--------|---|--|
| - | BGU8309 | 0.8 mm x 0.8 mm x 0.35 mm | | NXP | WLCSP |
| PCB | | 20 x 35mm | | BGU8309 GNSS LNA EV Kit | |
| C1 | Capacitor | 0402 | 1nF | Murata GRM1555 | Decoupling |
| L1 | Inductor | 0402 | 6.8 nH | Murata LQW15 | Input matching |
| X1, X2 | SMA RD connector | - | - | Johnson, End launch SMA 142-0701-841 | RF input/ RF output |
| X3 | DC header | - | - | Molex, PCB header, Right Angle, 1 row, 3 way 90121-0763 | Bias connector |
| X4 | JUMPER Stage | - | - | Molex, PCB header, Vertical, 1 row, 3 way 90120-0763 | Connect Ven to Vcc or separate Ven voltage |
| JU1 | JUMPER | | | | |

3.4 BGU8309 product description

NXP Semiconductors' BGU8309 GNSS low noise amplifier is designed for the GNSS frequency band. The integrated biasing circuit is temperature stabilized, which keeps the current constant over temperature. It also enables the superior linearity performance of the BGU8309. The BGU8309 is also equipped with an enable function that allows it to be controlled via a logic signal. In disabled mode it consumes less than 1 μ A.

The output of the BGU8309 is internally matched for 1575.42 MHz whereas only one series inductor at the input is needed to achieve the best RF performance. Both the input and output are AC coupled via an integrated capacitor.

It requires only two external components to build a GNSS LNA having the following advantages:

- Low noise
- System optimized gain
- High linearity under jamming
- 0.8 mm x 0.8 mm x 0.35 mm: SOT1226
- Low current consumption
- Short power settling time

3.5 Series inductor

The evaluation board is supplied with Murata LQW15 series inductor of 6.8 nH. This is a wire wound type of inductor with high quality factor (Q) and low series resistance (Rs) (see Table 2). This type of inductor is recommended in order to achieve the best noise performance. High Q inductors from other suppliers can be used. If it is decided to use other low cost inductors with lower Q and higher Rs the noise performance will degrade.

Table 2. Series Inductor options

| Type | Murata | Size 0201 | Size 0402 | Size 0603 | Comment |
|---------------------------------|--------|--------------|-----------------------|--------------|-----------|
| Multilayer Non-Magnetic Core | LQG | | 15H NF↑↑ | 18H NF↑ | |
| Film | LQP | 03T NF↑↑ | 15M NF↑ | | |
| Wirewound Non-Magnetic Core | LQW | | 15A Default | 18A NF↓ | Lowest NF |

4. Typical LNA evaluation board results

At the average power levels of -130 dBm that have to be received by a GNSS receiver, the system will not have in-band intermodulation problems caused by the GNSS-signal itself. Strong out-of-band cell phone TX jammers however can cause linearity problems and result in third-order intermodulation products in the GNSS frequency band. In this Chapter the effects of these jammer-signals on the Noise and Gain performance of the BGU8309 are described. The effect of these Jammers on the In-band and Out-of-Band Third-Order Intercept points are described in more detail in a separate User Manual: UM10453: 2-Tone Test BGU7005 and BGU7007 GNSS LNA.

4.1 In-band 1dB gain compression due to 850MHz and 1850MHz jammers

As stated before, signal levels in the GNSS frequency band of -130 dBm average will not cause linearity problems in the GNSS band itself. This of course is also valid for the 1dB gain compression in-band. The 1dB compression point at 1575.42MHz caused by cell phone TX jammers however is important.

Measurements have been carried out using the setup shown in Fig 5.

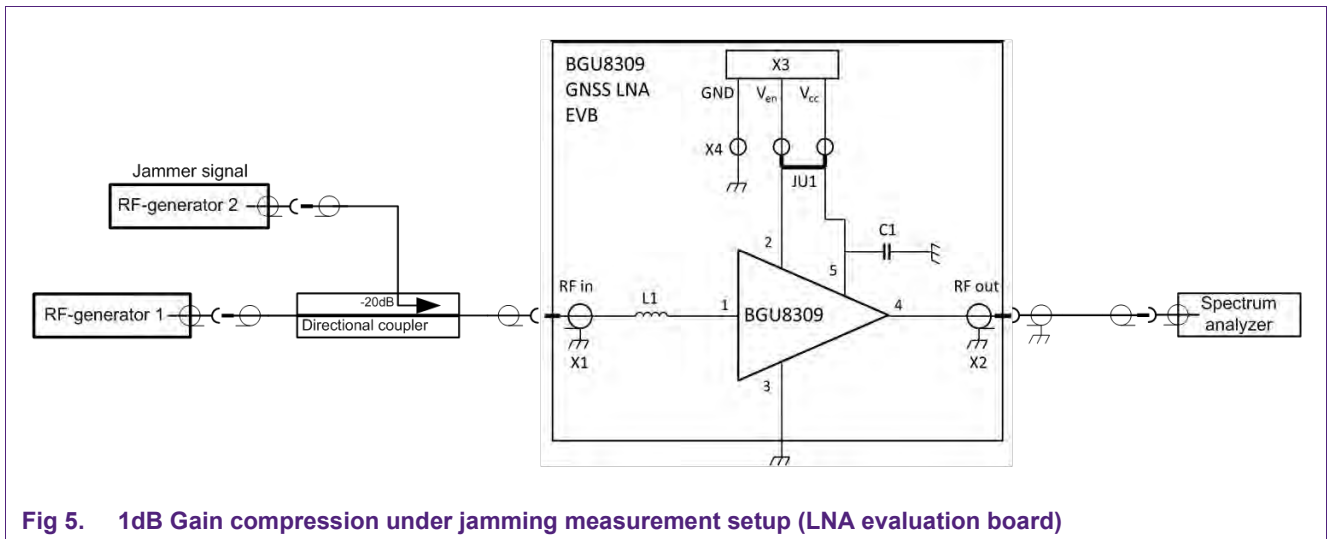
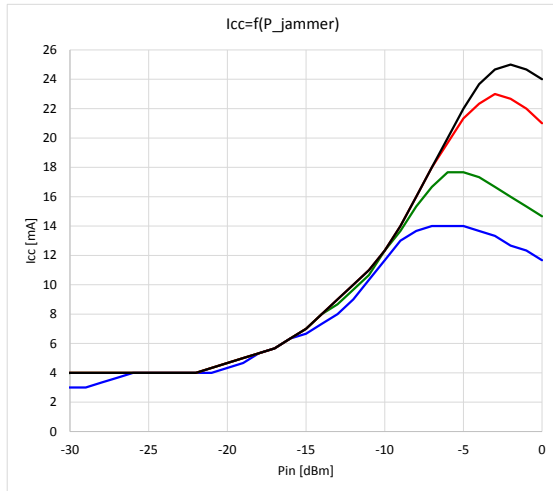

Fig 5. 1dB Gain compression under jamming measurement setup (LNA evaluation board)

The gain of the DUT was measured between port RFin and RFout of the EVB at the GNSS frequency 1575 MHz, while simultaneously a jammer power signal was swept at the 20dB attenuated input port of the Directional Coupler. Please note that the drive power of the jammer is 20 dB lower at the input of the DUT caused by the directional coupler.

The figures below show the supply-current (I_{cc}) and gain compression curves with 850MHz and 1850 MHz jammers (input jammer power at LNA-board, taking into account the approx. 20 dB attenuation of the directional coupler and RF-cable from Jammer-Generator to the directional coupler).

The gain drops 1dB with approximately -12 dBm input jamming power and 850MHz ($V_{cc}=1.8V$) (Fig 7). With an 1850MHz jamming signal, the 1dB gain compression occurs around -8 dBm input power level (Fig 9).



Pin 1575 MHz = -45 dBm, Tamb=25 °C

Fig 6. Icc versus jammer power at 850 MHz

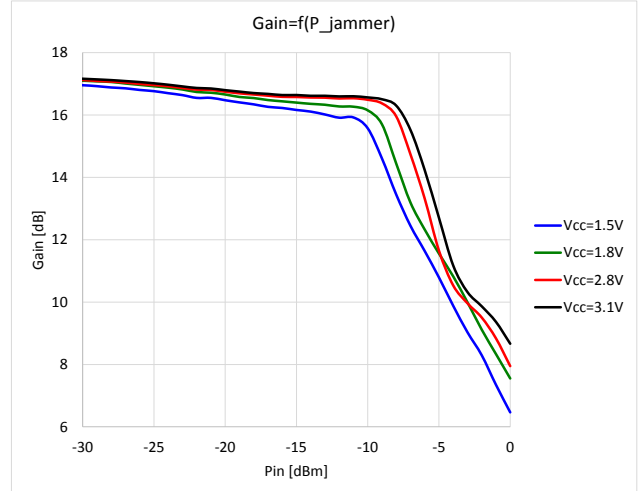

Pin 1575 MHz = -45 dBm, Tamb=25 °C

Fig 7. Gain versus jammer power at 850 MHz

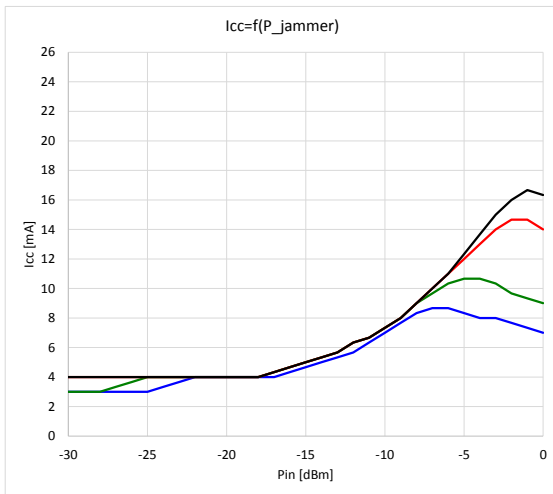

Pin 1575 MHz = -45 dBm, Tamb=25 °C

Fig 8. Icc versus jammer power at 1850 MHz

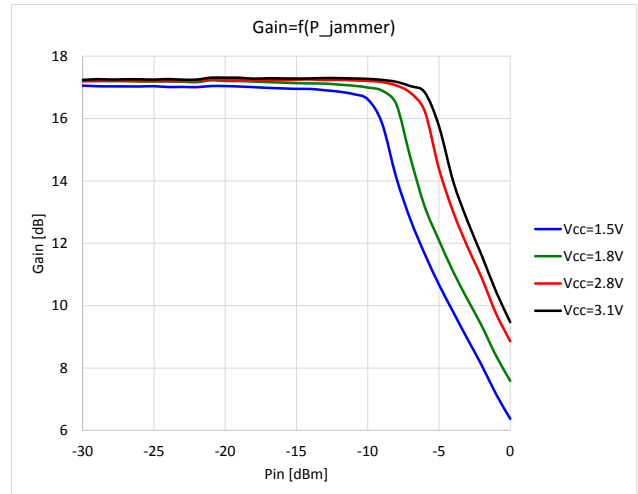

Pin 1575 MHz = -45 dBm, Tamb=25 °C

Fig 9. Gain versus jammer power at 1850 MHz

4.2 Noise figure as function of jammer power at 850MHz and 1850MHz

Noise figure under jamming conditions is a measure of how the LNA behaves when e.g. a GSM TX interfering signal is at the input of the GNSS antenna. To measure this behavior the setup shown in Fig 10 is used.

The jammer signal is coupled via a directional coupler to the DUT: this is to avoid the jammer signal damaging the noise source. The GNSS BPF is needed to avoid driving the second-stage LNA in saturation.

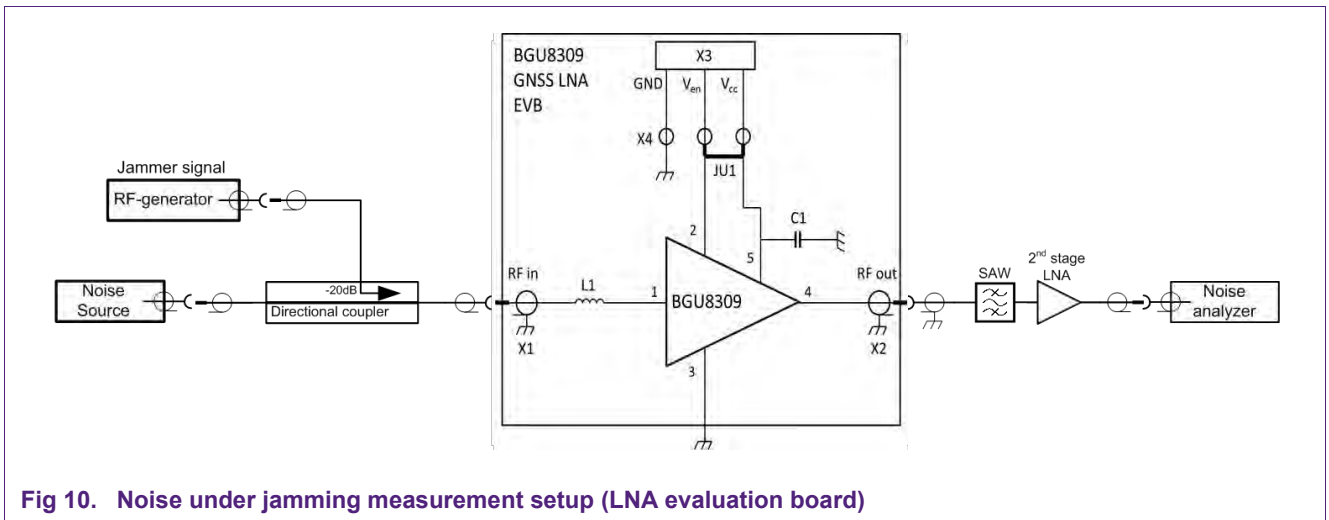
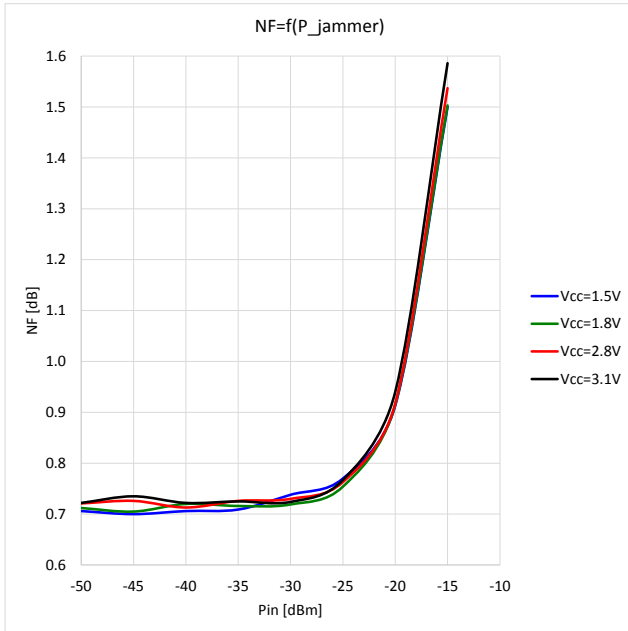

Fig 10. Noise under jamming measurement setup (LNA evaluation board)

With the results of these measurements and the specification of the SAW filter, the jammer power levels that cause noise increase can be calculated.

As can be seen in Fig 11, with a 850 MHz jammer the NF of the LNA starts to increase at $P_{jam} = -30$ dBm (input jammer power at LNA-board, taking into account the approx. 20 dB attenuation of the directional coupler and RF-cable from Jammer-Generator to the directional coupler). For the 1850 MHz jammer the NF of the LNA starts to increase at $P_{jam} = -35$ dBm (see Fig 12).



Pin 1575 MHz = -45 dBm, Tamb=25 °C
Including PCB losses.

Fig 11. NF versus jammer power at 850 MHz

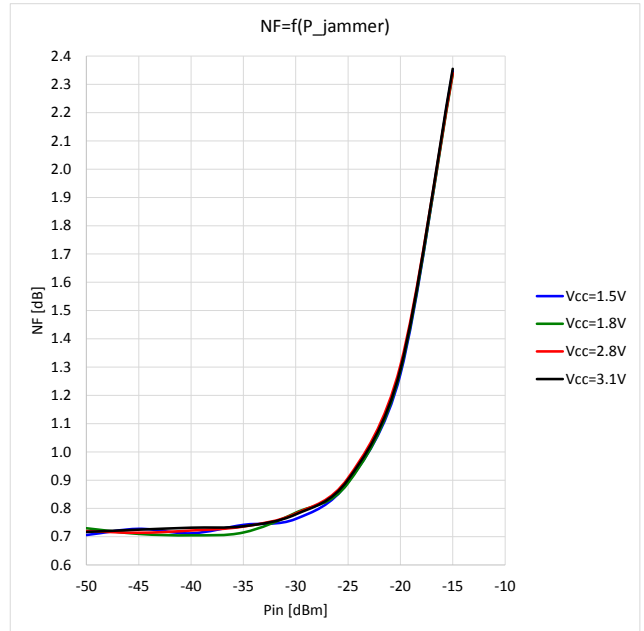

Pin 1575 MHz = -45 dBm, Tamb=25 °C
Including PCB losses.

Fig 12. NF versus jammer power at 1850 MHz

5. Required Equipment

In order to measure the evaluation board the following is necessary:

- ✓ DC Power Supply up to 30 mA at 1.5 V to 3.1 V
- ✓ Two RF signal generators capable of generating RF signals at the operating frequency of 1575.42 MHz, as well as the jammer frequencies 1713.42 MHz and 1851.42 MHz
- ✓ An RF spectrum analyzer that covers at least the operating frequency of 1575.42 MHz as well as a few of the harmonics. Up to 6 GHz should be sufficient.
“Optional” a version with the capability of measuring noise figure is convenient
- ✓ Amp meter to measure the supply current (optional)
- ✓ A network analyzer for measuring gain, return loss and reverse isolation
- ✓ Noise figure analyzer and noise source
- ✓ Directional coupler
- ✓ Proper RF cables

6. Connections and setup

The BGU8309 GNSS LNA evaluation board is fully assembled and tested. Please follow the steps below for a step-by-step guide to operate the LNA evaluation board and testing the device functions.

1. Connect the DC power supply to the V_{cc} and GND terminals. Set the power supply to the desired supply voltage, between 1.5 V and 3.1 V, but never exceed 3.1 V as it might damage the BGU8309.
2. Jumper JU1 is connected between the V_{cc} terminal of the evaluation board and the V_{en} pin of the BGU8309.
3. Connect the RF signal generator and the spectrum analyzer to the RF input and the RF output of the evaluation board, respectively. Do not turn on the RF output of the signal generator yet, set it to -45 dBm output power at 1575.42 MHz, set the spectrum analyzer at 1575.42 MHz center frequency and a reference level of 0 dBm.
4. Turn on the DC power supply and it should read approximately 3.6 mA.
5. Enable the RF output of the generator: The spectrum analyzer displays a tone around -28 dBm at 1575.42 MHz.
6. Instead of using a signal generator and spectrum analyzer one can also use a network analyzer in order to measure gain as well as in- and output return loss.
7. For noise figure evaluation, either a noise figure analyzer or a spectrum analyzer with noise option can be used. The use of a 5 dB noise source, like the Agilent 364B is recommended. When measuring the noise figure of the evaluation board, any kind of adaptors, cables etc between the noise source and the evaluation board should be minimized, since this affects the noise figure.

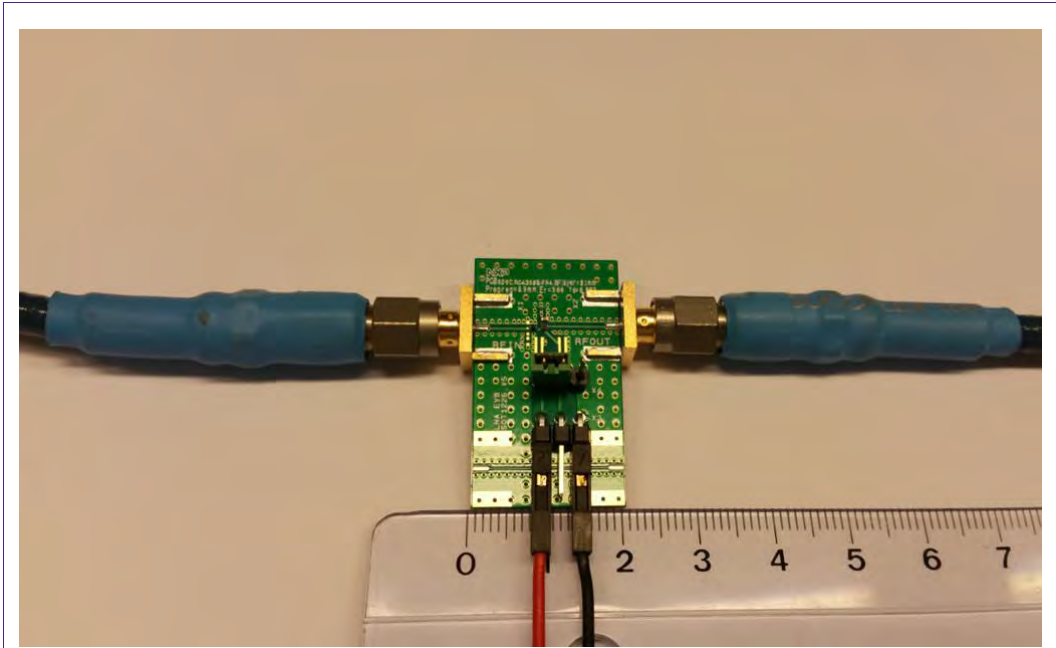

Fig 13. Evaluation board including its connections

7. Legal information

7.1 Definitions

Draft — The document is a draft version only. The content is still under internal review and subject to formal approval, which may result in modifications or additions. NXP Semiconductors does not give any representations or warranties as to the accuracy or completeness of information included herein and shall have no liability for the consequences of use of such information.

7.2 Disclaimers

Limited warranty and liability — Information in this document is believed to be accurate and reliable. However, NXP Semiconductors does not give any representations or warranties, expressed or implied, as to the accuracy or completeness of such information and shall have no liability for the consequences of use of such information. NXP Semiconductors takes no responsibility for the content in this document if provided by an information source outside of NXP Semiconductors.

In no event shall NXP Semiconductors be liable for any indirect, incidental, punitive, special or consequential damages (including - without limitation - lost profits, lost savings, business interruption, costs related to the removal or replacement of any products or rework charges) whether or not such damages are based on tort (including negligence), warranty, breach of contract or any other legal theory.

Notwithstanding any damages that customer might incur for any reason whatsoever, NXP Semiconductors' aggregate and cumulative liability towards customer for the products described herein shall be limited in accordance with the Terms and conditions of commercial sale of NXP Semiconductors.

Right to make changes — NXP Semiconductors reserves the right to make changes to information published in this document, including without limitation specifications and product descriptions, at any time and without notice. This document supersedes and replaces all information supplied prior to the publication hereof.

Suitability for use — NXP Semiconductors products are not designed, authorized or warranted to be suitable for use in life support, life-critical or

safety-critical systems or equipment, nor in applications where failure or malfunction of an NXP Semiconductors product can reasonably be expected to result in personal injury, death or severe property or environmental damage. NXP Semiconductors and its suppliers accept no liability for inclusion and/or use of NXP Semiconductors products in such equipment or applications and therefore such inclusion and/or use is at the customer's own risk.

Applications — Applications that are described herein for any of these products are for illustrative purposes only. NXP Semiconductors makes no representation or warranty that such applications will be suitable for the specified use without further testing or modification.

Customers are responsible for the design and operation of their applications and products using NXP Semiconductors products, and NXP Semiconductors accepts no liability for any assistance with applications or customer product design. It is customer's sole responsibility to determine whether the NXP Semiconductors product is suitable and fit for the customer's applications and products planned, as well as for the planned application and use of customer's third party customer(s). Customers should provide appropriate design and operating safeguards to minimize the risks associated with their applications and products.

NXP Semiconductors does not accept any liability related to any default, damage, costs or problem which is based on any weakness or default in the customer's applications or products, or the application or use by customer's third party customer(s). Customer is responsible for doing all necessary testing for the customer's applications and products using NXP Semiconductors products in order to avoid a default of the applications and the products or of the application or use by customer's third party customer(s). NXP does not accept any liability in this respect.

Export control — This document as well as the item(s) described herein may be subject to export control regulations. Export might require a prior authorization from national authorities.

7.3 Trademarks

Notice: All referenced brands, product names, service names and trademarks are property of their respective owners.

8. List of figures

| | | |
|---------|--|----|
| Fig 1. | BGU8309 GNSS LNA evaluation board..... | 3 |
| Fig 2. | Circuit diagram of the BGU8309 LNA evaluation board..... | 4 |
| Fig 3. | Printed-Circuit Board layout of the BGU8309 LNA evaluation board with detail of the footprint (right). | 5 |
| Fig 4. | Stack of the PCB material | 6 |
| Fig 5. | 1dB Gain compression under jamming measurement setup (LNA evaluation board)..... | 9 |
| Fig 6. | Icc versus jammer power at 850 MHz..... | 10 |
| Fig 7. | Gain versus jammer power at 850 MHz..... | 10 |
| Fig 8. | Icc versus jammer power at 1850 MHz..... | 10 |
| Fig 9. | Gain versus jammer power at 1850 MHz..... | 10 |
| Fig 10. | Noise under jamming measurement setup (LNA evaluation board) | 11 |
| Fig 11. | NF versus jammer power at 850 MHz..... | 12 |
| Fig 12. | NF versus jammer power at 1850 MHz..... | 12 |
| Fig 13. | Evaluation board including its connections | 14 |

9. List of tables

Table 1. BOM of the BGU8309 GNSS LNA evaluation board.....7

Table 2. Series Inductor options8

10. Contents

| | | |
|------------|---|-----------|
| 1. | Introduction | 3 |
| 2. | General description..... | 4 |
| 3. | BGU8309 GNSS LNA evaluation board | 4 |
| 3.1 | Application Circuit | 4 |
| 3.2 | PCB Layout..... | 5 |
| 3.3 | Bill of materials..... | 7 |
| 3.4 | BGU8309 product description | 7 |
| 3.5 | Series inductor | 7 |
| 4. | Typical LNA evaluation board results | 9 |
| 4.1 | In-band 1dB gain compression due to 850MHz and 1850MHz jammers | 9 |
| 4.2 | Noise figure as function of jammer power at 850MHz and 1850MHz | 11 |
| 5. | Required Equipment | 13 |
| 6. | Connections and setup..... | 13 |
| 7. | Legal information | 15 |
| 7.1 | Definitions | 15 |
| 7.2 | Disclaimers..... | 15 |
| 7.3 | Trademarks | 15 |
| 8. | List of figures..... | 16 |
| 9. | List of tables | 17 |
| 10. | Contents..... | 18 |

Please be aware that important notices concerning this document and the product(s) described herein, have been included in the section 'Legal information'.

© NXP B.V. 2016.

All rights reserved.

For more information, visit: <http://www.nxp.com>

For sales office addresses, please send an email to: salesaddresses@nxp.com

Date of release: 12 August 2016

Document identifier: AN11729