



MOTOR CONTROL SOLUTIONS BASED ON S32K3 MCUS

The S32K3 family of 32-bit AEC-Q100 qualified MCUs combines a scalable family of Arm® Cortex-M7-based microcontrollers built on long-lasting features with a comprehensive suite of production-grade tools. S32K3 MCUs are included in NXP's Product Longevity Program, guaranteeing a minimum of 15 years of assured supply.

S32K3 VALUE PROPOSITION FOR MOTOR CONTROL

SCALABLE MCU PLATFORM

- Hardware- and Software- compatible MCU family
- 120 – 240 MHz Arm Cortex-M7 core
- Flash memory: from 512 KB up to 8 MB
- MAPBGA, HDQFP packages, from 48 to 289 pin count
- CAN FD, FlexIO, QSPI, Ethernet and serial audio interfaces
- AEC-Q100 qualified:
 - Grade 1 (-40° C to +125° C)
 - Grade 2 (-40° C to +105° C)
- Functional Safety compliant: ISO 26262 up to ASIL D
- Hardware Security Engine (HSE): AES-128/192/256, RSA and ECC encryption, ISO 21434 intended

MOTOR CONTROL COVERAGE

- Engineered tools for 3-phase PMSM and 3-phase BLDC motor control targeting body and chassis
- Dedicated peripherals set for rapid motor control loop implementation: enhanced Modular IO Subsystem (eMIOS), Logic Control Unit (LCU), TRGMUX, Body Cross-triggering Unit (BCTU), Analog to Digital Converter (ADC), and Analog Comparator (CMP)

COMPREHENSIVE MOTOR CONTROL ECOSYSTEM

- Diverse hardware solutions supporting motor control applications
- S32K3 software ecosystem with production-ready algorithm library:
 - Automotive Math and Motor Control Library (AMMCLib) set
 - FreeMASTER and Motor Control Application Tuning (MCAT) tool
 - Model-Based Design Toolbox (MBDT)
- Dedicated technical support and online community



S32K3 PRODUCT OVERVIEW

S32K3 provides a scalable platform with high hardware and software compatibility to address various motor control techniques and applications.

S32K310	S32K311	S32K312	S32K314	S32K322	S32K324	S32K341	S32K342	S32K344	S32K328	S32K338	S32K348	S32K358
1x Cortex-M7 @ 120 MHz			1x Cortex-M7 @ 160 MHz	2x Cortex-M7 @ 160 MHz		1x LS Cortex-M7 @ 160MHz			2x Cortex-M7 @ 160 MHz	3x Cortex-M7 @ 240 MHz	1x LS Cortex-M7 @ 160 MHz	1x LS Cortex-M7 + 1x Cortex-M7 @ 240 MHz
ASIL B	ASIL B	ASIL B	ASIL B	ASIL B	ASIL B	ASIL D	ASIL D	ASIL D	ASIL B	ASIL B	ASIL D	ASIL D
512 KB Flash	1 MB Flash	2 MB Flash	4 MB Flash	2 MB Flash	4 MB Flash	1 MB Flash	2 MB Flash	4 MB Flash	8 MB Flash			
64K SRAM incl. 64K TCM	128K SRAM incl. 96K TCM	192K SRAM incl. 96K TCM	512K SRAM incl. 96K TCM	256K SRAM incl. 192K TCM	512K SRAM incl. 192K TCM	256K SRAM incl. 192K TCM	256K SRAM incl. 192K TCM	512K SRAM incl. 192K TCM	1152K SRAM			
up to 84 I/Os	up to 84 I/Os	up to 143 I/Os	up to 218 I/Os	up to 143 I/Os	up to 218 I/Os	up to 143 I/Os	up to 143 I/Os	up to 218 I/Os	up to 218 I/Os			
16 channel eDMA			32 ch eDMA	32 channel eDMA					32 channel eDMA			
3x FlexCAN w/CAN-FD		6x FlexCAN w/CAN-FD		4x FlexCAN w/CAN-FD	6x FlexCAN w/CAN-FD	4x FlexCAN w/CAN-FD	4x FlexCAN w/CAN-FD	6x FlexCAN w/CAN-FD	8x FlexCAN w/CAN-FD			
			1x 100 Mbps Ethernet (TSN)	1x 100 Mbps Ethernet (TSN)					1x 1 Gbps Ethernet (TSN)			
2x I2C			2x I2C	2x I2C	2x I2C	2x I2C	2x I2C	2x I2C	2x I2C			
4x SPI**			6x SPI**	4x SPI**	6x SPI**	4x SPI**	4x SPI**	6x SPI**	6x SPI**			
2x 24 ch 12-bit ADC			3x 24 ch 12-bit ADC	2x 24 ch 12-bit ADC	3x 24 ch 12-bit ADC	2x 24 ch 12-bit ADC	2x 24 ch 12-bit ADC	3x 24 ch 12-bit ADC	3x 24 ch 12-bit ADC			
			2 x SAI (I2S)	2x SAI (I2S)					2x SAI (I2S)			
			Quad SPI	Quad SPI					Quad SPI			
									SDHC(SDIO)			
LQFP-48		HDQFP-172		HDQFP-172					HDQFP-172			
HDQFP-100				HDQFP-100		HDQFP-100	HDQFP-100					
			MAPBGA-257		MAPBGA-257			MAPBGA-257	MAPBGA-289			

Common HW: HSE B, LPUART, FlexIO, eMIOS Timers, ACMP, LCU, BCTU, TRGMUX
Common SW: Real Time Driver, Security FM, Safety Framework SW & Core Self Test Lib, Application Specific SW

**Ethernet 10BaseT1S supported by SPI + external MAC&PHY

S32K3 MOTOR CONTROL LINEUP

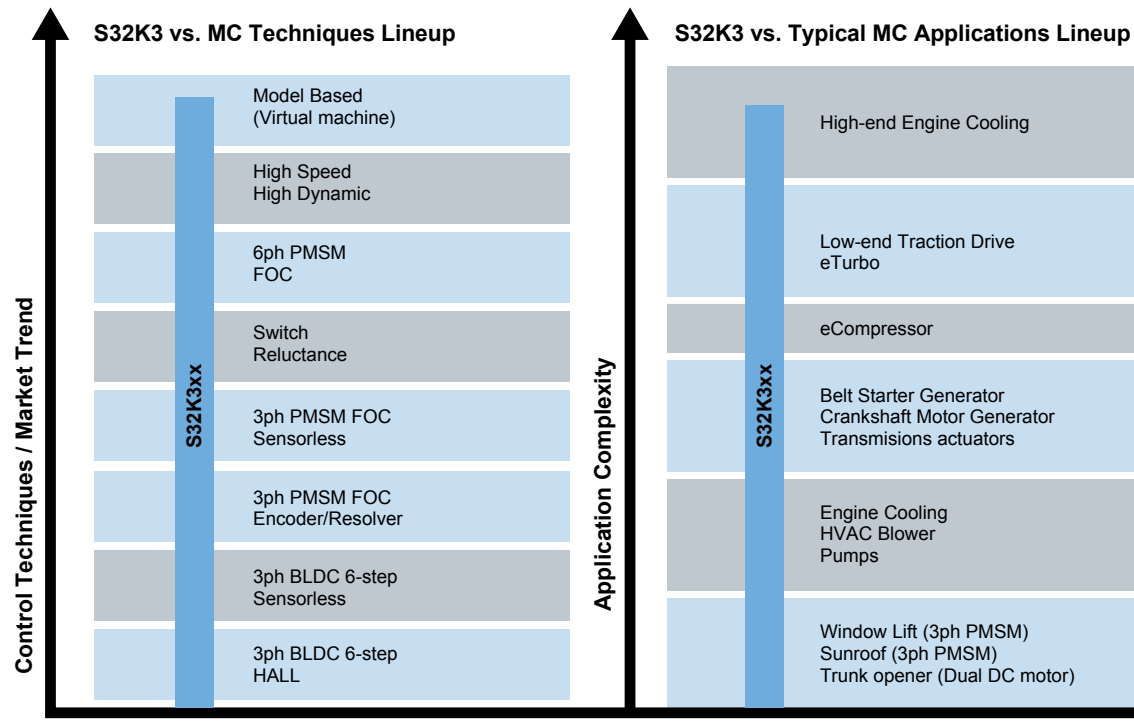

S32K3 MOTOR CONTROL SOFTWARE AND ECOSYSTEM

AUTOMOTIVE MATH AND MOTOR CONTROL LIBRARY (AMMCLIB) SET

- Precompiled software library including NXP-patented control math algorithms
- Automotive production-ready software (SPICE Level 3, CMMI and ISO 9001/TS 16949)
- Delivered as bit-accurate models for MATLAB®/Simulink® and C code
- Single API across NXP MCUs, simple migration across platforms

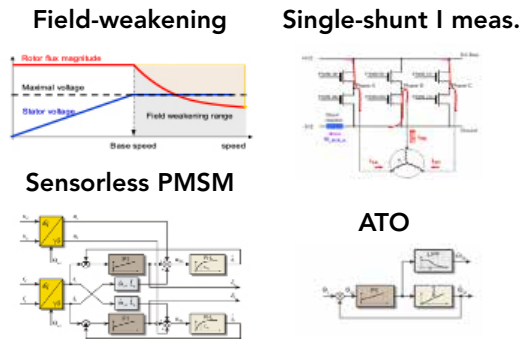

MODEL-BASED DESIGN TOOLBOX (MBDT)

- Model-based design environment in MATLAB® and Simulink® for motor control software on S32K MCUs
- Automatic code generation for S32K3xx peripherals and applications prototyping
- Extensive online community and tutorials available
- Model-based design approach helps to save R&D time and test efforts

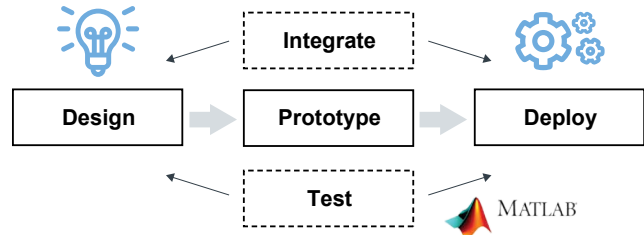

FREEMASTER (LITE)

- Real-time data visualization tool for debugging and tuning embedded algorithm during development
- Graphs, tabular grids and web views embedded directly in the desktop application
- FreeMASTER Lite supports JSON RPC protocol and is able to run on Windows® or Linux® host PC, enabling custom UI on web browsers

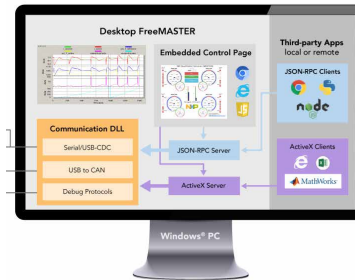

MOTOR CONTROL APPLICATION TUNING (MCAT)

- HTML-based graphical user interface tool, plug-in to FreeMASTER and fully compliant with AMMCLib set API
- Real-time tuning and updating of control parameters





S32K3 ADDITIONAL SOFTWARE

- S32 Design Studio IDE: Eclipse, GCC and debugger
- Security firmware: NXP provided
- Core Self-Test Library for functional safety applications
- Production-grade ASIL compliant Real Time Drivers (RTD) support for both AUTOSAR and non-AUTOSAR applications
- Third-party ecosystem support to reduce time-to-market



S32K3 MOTOR CONTROL HARDWARE TOOLS

Part number	MCSPT1AK344
	
PRODUCTS	
MCU	S32K344
Analog	GD3000: MOSFET gate driver for 3-phase motor FS26: Safety System Basis Chip (SBC) with Low-Power Fit for ASIL D TJA1021: LIN 2.1/SAE J2602 Transceiver TJA1043 HS-CAN Transceiver
HARDWARE	
Motor	3-phase BLDC motor with Hall sensor, 24 VDC, 9000 RPM, 95 W
Power	Up to 100 W
Voltage	12 V (10-18 V)
Current sensing	Single-, dual- and triple-shunt
Position sensing	Hall, encoder
Communication	CAN (FD), LIN, Ethernet, UART, PWM
MOTOR CONTROL SOFTWARE APPLICATION	
PMSM FOC	3-phase field-oriented control (FOC) with field weakening (FW) Sensor (Encoder) or sensorless control (back-EMF observer) Single-shunt and triple-shunt current sensing and 3-phase stator current reconstruction Examples built on either RTD high-level API (Autosar & non-Autosar applications) or low-level API (non-Autosar) applications
BLDC Six-step	3-phase 6-step commutation control Sensor (Hall) or sensorless control based on back-EMF zero-cross detection method
TOOLS	
Integrated development environment	S32 Design Studio IDE for S32 Platform
MCU peripherals settings and control	Real Time Drivers (RTD)
Motor control library	Automotive Math and Motor Control Library (AMMCLib) set
Visualization and motorcontrol tuning	FreeMASTER and Motor Control Application Tuning (MCAT)

Part number	MCTPTX1AK324 available in June 2023
	
PRODUCTS	
MCU	S32K324
Analog	GD3000: MOSFET gate driver for 3-phase motor FS26: Safety System Basis Chip (SBC) with Low-Power Fit for ASIL D TJA1021: LIN 2.1/SAE J2602 Transceiver TJA1043: HS-CAN Transceiver HB2001: SPI Programmable 10 A H-Bridge Brushed DC Motor Driver MC40XS6500: High-Side Switch, 12V
HARDWARE	
Power	12V (8 - 18V), 5Amps RMS -> ~100
Current sensing	Dual shunt
Position sensing	Sensorless
Other	Integrated thermal management unit
Communication	HS-CAN, LIN, USB to UART
MOTOR CONTROL SOFTWARE APPLICATION	
PMSM	Field-oriented control (FOC) with field weakening for sinusoidal motor type Support control 3x PMSM, 1x DCM and 4x valves, independently Available as ANSI C examples in versions for non-Autosar applications
TOOLS	
Integrated development	S32 Design Studio IDE for S32 Platform
MCU peripherals settings and control	Real Time Drivers (RTD)
Motor control library	Automotive Math and Motor Control Library (AMMCLib) set
Visualization and motor control tuning	FreeMASTER and Motor Control Application Tuning (MCAT)

S32K3 MOTOR CONTROL BLOCK DIAGRAMS

FIELD ORIENTED CONTROL (FOC) FOR PMSM MOTOR

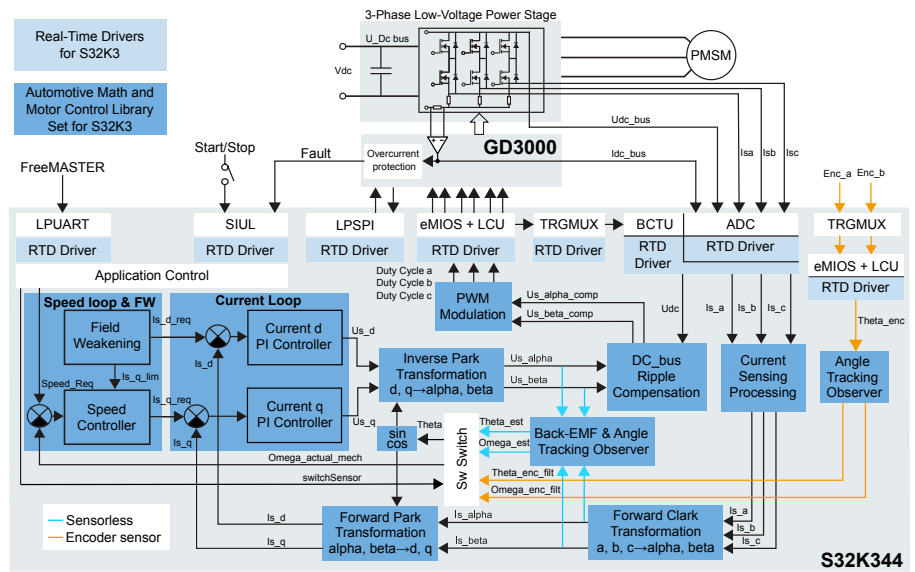

SIX-STEP COMMUTATION CONTROL FOR BLDC MOTOR

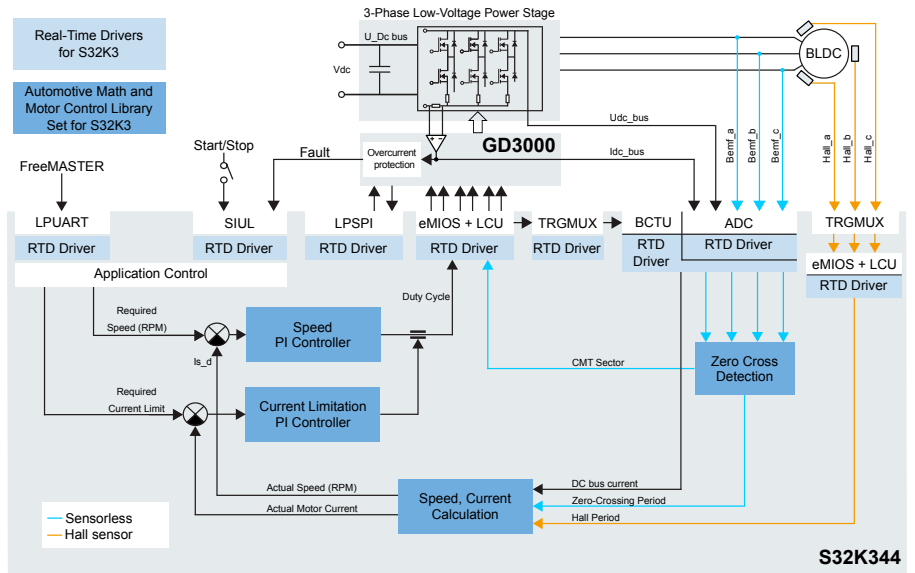

S32K3 RESOURCES

S32K3 MCUs
nxp.com/S32K3

MBDT online support
nxp.com/MBDTcommunity

FreeMASTER Run-Time Debugging Tool
nxp.com/FreeMaster

S32K Motor Control Development kits
nxp.com/S32KMCdevKits

S32 Design Studio IDE
nxp.com/S32DS

AMMCLib set
nxp.com/AMMCLib

S32K online support
nxp.com/S32Kcommunity

Model-Based Design Toolbox
nxp.com/MBDT

nxp.com/S32KMCdevKits

NXP, the NXP logo and Processor Expert are trademarks of NXP B.V. All rights reserved. All other product or service names are the property of their respective owners. Arm and Cortex are trademarks or registered trademarks of Arm Limited (or its subsidiaries) in the US and/or elsewhere. MATLAB and Simulink are registered trademarks of The MathWorks, Inc. The related technology may be protected by one or all of patents, copyrights, designs and trade secrets. © 2023 NXP B.V.

Document Number: S32K3MCBROCH REV 4