

# NXP NVT4555, NVT4557 AND NVT4558 SIM CARD LEVEL TRANSLATOR

# NXP NVT4857 AND NVT4858 SD AND SIM CARD LEVEL TRANSLATORS

NXP offers SD and SIM Card Level Translators: With and without LDO, with outstanding ESD protection and EMI filter, in space saving WLCSP packages and lower cost XQFN plastic package options and with High Clock Speeds!

Over 200 MHz clock, high ESD protection, and voltage level translation down to 1.08 V seamlessly interfaces SD 3.0 and legacy SD cards to low voltage MCUs and SOCs.

## WHAT IS A SIM CARD?

A subscriber identity module or subscriber identification module (SIM), widely known as a SIM card, is an integrated circuit running a card operating system (COS) that securely stores the international mobile subscriber identity (IMSI) number and its related key.



## WHAT IS A SD CARD?

Secure Digital, officially abbreviated as SD, is a proprietary, non-volatile memory card format developed by the SD Association (SDA) Such as mobile phones and digital cameras for use in portable devices to store digital information.



## WHY IS VOLTAGE TRANSLATION NEEDED?

Many SD and SIM cards start operation at 3 V or 1.8 V. The host is normally using an advanced process which has supply of 1.8 V, 1.2 V or even lower. The voltage level translator provides proper signal level to host (A side) and card (B side).

## WHY USE NXP VOLTAGE TRANSLATORS?

NXP has a highly skilled team that designs the product optimality, and as a large supplier of semiconductors, optimizes cost and efficiency. Additionally, the voltage level translation devices add ESD protection and EMI filter to save external components.

## WHY USE INTERNAL VS EXTERNAL LDO?

Internal or external LDO depends on the PMIC and baseband chip selection to allow customers to optimize cost or performance based on phone model requirements.

## QUALCOMM REFERENCE DESIGN USES LEVEL TRANSLATORS WITH EXTERNAL LDO

NVT4557 and NVT4558 SIM Card  
The reference design integrates the NVT4557HK and NVT4558HK, the 10-pin package SIM-card VLT with EN pin and not the 9-pin WLCSP package NVT4557UK (without EN pin). The EN pin meets the ISO standards related to the start-up / shut-down sequence between the host and SIM card. The final decision between 10-pin and 9-pin depends on the OEMs, trading off shut-down sequence with the smaller package size that has auto shut down based on V<sub>CCB</sub> supply. The NVT4557HK is optimized for 1.8 V processor interface and the NVT4558 for 1.2 V with  $0.65 \times V_{CCA}$  V<sub>IH</sub> and  $0.35 \times V_{CCA}$  V<sub>IL</sub> HOST interface.

### NVT4858 SD Card

The reference design uses the 16-pin package WLCSP package NVT4858UK because of its smaller size vs the lower price of the NVT4858HK (smaller die in plastic package). The final decision on package will depend on OEM, trading off board space vs component cost.

### TARGET FUNCTION

Secure Digital (SD3.0) and SIM Voltage Level Translation CLASS B,C

### END APPLICATION

Smartphones, Tablets, Digital Cameras, Wireless Modems

## TYPICAL APPLICATION WITH EXTERNAL LDO

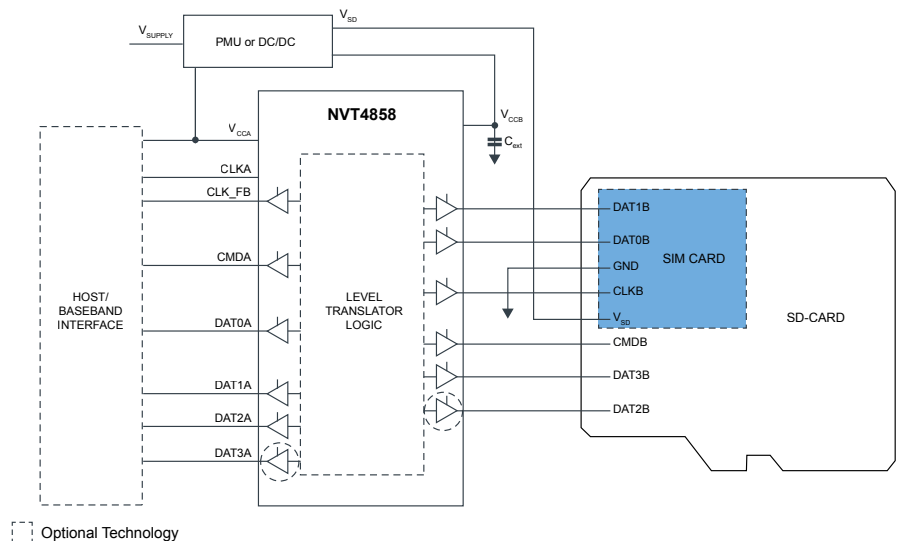

## SELECTION INFORMATION

EXTERNAL LDO					
Application	Part Number	Package Option	HOST Voltage Range (V)	Card Voltage Range (V)	LDO Voltage Range (V)
SIM 1.8 V Host	NVT4557	WLCSP9 and XQFN10	1.08 to 1.98	1.62 to 3.6	NA
SIM 1.2 and 1.8 V Host	NVT4558	XQFN10	1.08 to 1.98	1.62 to 3.6	NA
SD and SIM	NVT4858	WLCSP16 and XQFN16	1.08 to 1.98	1.62 to 3.6	NA

INTERNAL LDO					
Application	Part Number	Package Option	HOST Voltage Range (V)	Card Voltage Range (V)	LDO Voltage Range (V)
SIM	NVT4555	WLCSP12	1.1 to 3.6	1.8 or 2.95	2.5 to 5.25
SD and SIM	NVT4857	WLCSP20	1.1 to 2.0	1.8 or 3.0	2.9 to 3.6

ORDERING INFORMATION					
Part Number	Package	Package Size (mm)	Package Pitch (mm)	Minimum Order Quantity	Orderable Part Number
NVT4555UK	WLCSP12	1.19 x 1.62 x 0.56	0.40	3000	NVT4555UKZ
NVT4557UK	WLCSP9	0.91 x 0.91 x 0.525	0.30	20000	NVT4557UKZ
NVT4557HK	XQFN10	1.4 x 1.8 x 0.5	0.40	4000	NVT4557HKX
NVT4558HK	XQFN10	1.4 x 1.8 x 0.5	0.40	4000	NVT4558HKX
NVT4857UK	WLCSP20	1.7 x 2.1 x 0.49	0.40	10000	NVT4857UKAZ
NVT4858UK	WLCSP16	2.6 x 1.8 x 0.5	0.35	3000	NVT4858UKZ
NVT4858HK	XQFN16	1.41 x 1.41 x 0.525	0.40	4000	NVT4858HKZ

All devices are shipped in 7" (except NVT4557UK and NVT4857UK in 13") Tape and Reel with Pin 1 in Q1/T1

All devices are temperature range of T<sup>amb</sup> = -40 °C to + 85 °C and ESD HBM 2 kV and Contact 8 kV

[www.nxp.com/VLT](http://www.nxp.com/VLT)

NXP and the NXP logo are trademarks of NXP B.V. All other product or service names are the property of their respective owners.  
© 2022 NXP B.V.

Document Number: NVT4LEILAFS REV 1